

# ioLogik 4000 Series User's Manual

---

Fourth Edition, December 2012

[www.moxa.com/product](http://www.moxa.com/product)



© 2012 Moxa Inc. All rights reserved.

# ioLogik 4000 Series User's Manual

The software described in this manual is furnished under a license agreement and may be used only in accordance with the terms of that agreement.

## Copyright Notice

© 2012 Moxa Inc. All rights reserved.

## Trademarks

The MOXA logo is a registered trademark of Moxa Inc.  
All other trademarks or registered marks in this manual belong to their respective manufacturers.

## Disclaimer

Information in this document is subject to change without notice and does not represent a commitment on the part of Moxa.

Moxa provides this document as is, without warranty of any kind, either expressed or implied, including, but not limited to, its particular purpose. Moxa reserves the right to make improvements and/or changes to this manual, or to the products and/or the programs described in this manual, at any time.

Information provided in this manual is intended to be accurate and reliable. However, Moxa assumes no responsibility for its use, or for any infringements on the rights of third parties that may result from its use.

This product might include unintentional technical or typographical errors. Changes are periodically made to the information herein to correct such errors, and these changes are incorporated into new editions of the publication.

## Technical Support Contact Information

[www.moxa.com/support](http://www.moxa.com/support)

### **Moxa Americas**

Toll-free: 1-888-669-2872  
Tel: +1-714-528-6777  
Fax: +1-714-528-6778

### **Moxa Europe**

Tel: +49-89-3 70 03 99-0  
Fax: +49-89-3 70 03 99-99

### **Moxa India**

Tel: +91-80-4172-9088  
Fax: +91-80-4132-1045

### **Moxa China (Shanghai office)**

Toll-free: 800-820-5036  
Tel: +86-21-5258-9955  
Fax: +86-21-5258-5505

### **Moxa Asia-Pacific**

Tel: +886-2-8919-1230  
Fax: +886-2-8919-1231

# Table of Contents

<b>1. Overview</b>	<b>1-1</b>
ioLogik 4000 System Overview	1-2
Package List	1-2
Product Features	1-3
Product Descriptions	1-3
Network Adaptors	1-3
Analog Input Modules	1-3
Analog Output Modules	1-3
Digital Input Modules	1-3
Digital Output Modules	1-4
Power Modules	1-4
Temperature Input Modules	1-4
Specifications	1-4
Adaptors	1-4
NA-4010	1-4
NA-4020/4021	1-5
Common Specifications for the NA-4010 and NA-4020/4021	1-5
Analog Input Modules	1-6
M-3802: 8 analog inputs, 4 to 20 mA, 12 bits	1-6
M-3810: 8 analog inputs, 0 to 10 V, 12 bits	1-6
Analog Output Modules	1-6
M-4402: 4 analog outputs, 4 to 20 mA, 12 bits	1-6
M-4410: 4 analog outputs, 0 to 10 V, 12 bits	1-7
Digital Input Modules	1-7
M-1800: 8 digital inputs, sink type, 24 VDC	1-7
M-1801: 8 digital inputs, source type, 24 VDC	1-7
M-1600: 16 digital inputs, sink type, 24 VDC	1-8
M-1601: 16 digital inputs, source type, 24 VDC	1-8
M-1450: 4 digital inputs, 110 VAC	1-8
M-1451: 4 digital inputs, 220 VAC	1-9
Digital Output Modules	1-9
M-2800: 8 digital outputs, sink type, 24 VDC, 0.5 A	1-9
M-2801: 8 digital outputs, source type, 24 VDC, 0.5 A	1-9
M-2600: 16 digital outputs, sink type, 24 VDC, 0.3 A	1-10
M-2601: 16 digital outputs, source type, 24 VDC, 0.3 A	1-10
M-2450: 4 relay outputs, 24-VDC/230-VAC, 2 A	1-10
Power Modules	1-11
M-7001: System power module	1-11
M-7002: Field power module	1-11
M-7804: 0 VDC	1-11
M-7805: 24 VDC	1-11
Temperature Input Modules	1-12
M-6200: 2 analog inputs, RTD: PT100, JPT100	1-12
M-6201: 2 analog inputs, thermocouple	1-12
<b>2. Hardware Installation</b>	<b>2-1</b>
System Architecture	2-2
Connecting the Network Adaptor to I/O Modules	2-3
Appearance	2-3
Installing I/O Modules on a DIN Rail	2-3
Removing I/O Modules from a DIN Rail	2-4
Installing an RTB (Removable Terminal Block)	2-4
Removing the RTB from the I/O Module	2-4
Installing the RTB on the I/O Module	2-5
Connecting the Power System	2-5
Connecting to the Network	2-5
NA-4010 Ethernet Network Adaptor	2-5
Connecting a Single Ethernet I/O Server	2-5
Ethernet Pin Assignments	2-6
NA-4020 RS-485 Network Adaptor	2-6
Connecting a Single Serial I/O Server	2-6
NA-4020 RS-485 Port Pin Assignment	2-6
NA-4021 RS-232 Network Adaptor	2-7
NA-4021 RS-232 Port Pin Assignment	2-7
LED Indicators	2-7
LED Indicators for Network Adaptors	2-7
NA-4010	2-7
NA-4020/4021	2-8
LED Indicators for I/O Modules	2-8

When to Use the Power Expansion Module .....	2-9
When to Use the Field Power Distributor .....	2-9
When to Use the Potential Distributor .....	2-9
Safety Notes .....	2-10
Installation and Cabling Precautions .....	2-10
Operating Precautions .....	2-10
<b>3. Getting Started .....</b>	<b>3-1</b>
Installing ioAdmin Utility .....	3-2
Configuring the NA-4010 Ethernet I/O System .....	3-2
Initializing the IP Address .....	3-2
Linking the Ethernet I/O System to ioAdmin .....	3-4
Auto Search .....	3-4
Manually enter the IP address .....	3-4
Password Protection .....	3-6
Reset to Default .....	3-6
How to Reset to Default .....	3-6
NA-4010 Ethernet Network Adaptor Default Values .....	3-7
System Restart .....	3-7
Deleting an I/O Server from the List .....	3-7
Network .....	3-7
TCP Socket Timeout Interval .....	3-8
Watchdog Timer .....	3-9
Firmware Upgrade .....	3-9
Exporting the System Configuration .....	3-10
Remote Monitoring .....	3-10
I/O Status Refresh Rate .....	3-10
Checking the Ethernet I/O Status via Web Browser (NA-4010 only) .....	3-10
Configuring the NA-4020/4021's RS-485/232 I/O System .....	3-12
Configuring Communication Parameters .....	3-12
Linking the RS-485/232 I/O Server to ioAdmin .....	3-13
Starting ioAdmin .....	3-13
Linking to the RS-232/485 Server .....	3-14
Password Protection .....	3-16
Reset to Default .....	3-16
Restarting the System .....	3-17
Deleting an I/O Server from the List .....	3-17
Watchdog Timer .....	3-17
Firmware Update .....	3-17
I/O Status Refresh Rate .....	3-17
Modbus Address Mapping .....	3-18
Finding a Modbus Address for I/O Channels .....	3-18
Exporting Modbus Address Settings .....	3-18
<b>4. Configuring I/O Modules .....</b>	<b>4-1</b>
On-Line Wiring Guide .....	4-2
Digital Input Modules .....	4-3
Digital Output Modules .....	4-4
Digital Output Module Safe Status .....	4-5
Analog Input Modules .....	4-6
Analog Output Modules .....	4-6
Analog Output Module Safe Status .....	4-7
Temperature Sensing Modules .....	4-8
RTD .....	4-8
Thermocouple .....	4-9
<b>5. MXIO DLL Library .....</b>	<b>5-1</b>
Overview .....	5-2
What is MXIO DLL Library? .....	5-2
How to install MXIO DLL Library .....	5-2
MXIO Function Groups .....	5-2
System Commands .....	5-2
Modbus Command Sets .....	5-2
Direct I/O Command Sets .....	5-3
<b>A. Pinouts and Cable Wiring .....</b>	<b>A-1</b>
Port Pinout Diagrams .....	A-2
Ethernet Port Pinouts .....	A-2
Serial Port Pinouts .....	A-2
NA-4020 RS-485 Network Adaptor Pin Assignment .....	A-2
NA-4021 RS-232 Network Adaptor Pin Assignment .....	A-2
Ethernet Cable Wiring Diagrams .....	A-3

The ioLogik 4000 is a standalone Active Ethernet I/O server that can connect sensors and on/off switches for automation applications over Ethernet and IP-based networks.

The following topics are covered in this chapter:

▣ **ioLogik 4000 System Overview**

▣ **Package List**

▣ **Product Features**

▣ **Product Descriptions**

- Network Adaptors
- Analog Input Modules
- Analog Output Modules
- Digital Input Modules
- Digital Output Modules
- Power Modules
- Temperature Input Modules

▣ **Specifications**

- Adaptors
- Analog Input Modules
- Analog Output Modules
- Digital Input Modules
- Digital Output Modules
- Power Modules
- Temperature Input Modules

# ioLogik 4000 System Overview

The ioLogik 4000 is a network I/O server that can connect sensors and on/off devices in any combination and can transfer the captured data or device status to a host computer via an Ethernet or RS-485/232 network.

The ioLogik 4000 consists of two main parts. The network adaptor provides system and field power to connected I/O modules. Three kinds of network adaptor are available: (1) Ethernet, (2) RS-485, and (3) RS-232. Up to 32 I/O modules can be connected to one network adaptor.



**Network  
Adaptor**

**I/O Expansion Modules**  
(supports up to 32 modules, with up to 512 DI/Os or 128 AIOs)

Network Adaptor	Digital Input		Digital Output		Analog Input		Analog Output		Special Modules	
	Type	Ch.	Type	Ch.	Type	Ch.	Type	Ch.	Type	Ch.
Ethernet	24 VDC	8,16	24 VDC	8,16	4-20 mA	8	4-20 mA	4	Encoder (24 V)	1
RS-485	48 VDC	4	125 VAC	4	0-10 V	8	0-10 V	4	–	–
RS-232	110 VAC	4	230 VAC	4	RTD	2	–	–	–	–
	230 VAC	4	–	–	TC	2	–	–	–	–

## Package List

Each Network Adaptor and I/O module is packed securely in a small cardboard box.

### Network Adaptor

- NA-40xx network adaptor
- Software CD-ROM

### I/O Module

- M-xxxx I/O module

### Contents of the Software CD-ROM

- ioAdmin utility for Windows
- User's Manual, Wiring Guide
- I/O module power calculation spreadsheet
- MXIO DLL library, examples, and documents
- Warranty booklet

## Product Features

Detailed specifications of ioLogik 4000 are available in the software's product specification help files. Refer to the help file for more information.

- Remotely acquire sensor data and control I/O points via Ethernet, RS-232, or RS-485.
- Supports up to 40 types of digital and analog I/O modules.
- Supports up to 32 modules for a maximum of 512 digital I/O points or 128 analog input channels.
- Modular, slice-type package with Removable Terminal Block for fast swap and maintenance.
- Supports standard Modbus/TCP up to 8 concurrent sessions for Ethernet Network Adaptors.
- Supports standard Modbus/RTU/ASCII for RS-485/RS-232 Network Adaptors.
- Easy-to-use ioAdmin utility for remote and local management.
- Easy-to-use DLL library for easy user programming.

## Product Descriptions

### Network Adaptors

Model Name	Description
NA-4010	Ethernet network adaptor Modbus/TCP
NA-4020	RS-485 network adaptor Modbus/RTU
NA-4021	RS-232 network adaptor Modbus/RTU

### Analog Input Modules

Model Name	Description
M-3802	8 AIs, current, 4-20 mA, 12-bit, RTB
M-3810	8 AI, voltage, 0-10 V, 12-bit, RTB
M-6200	2 AI, RTD:PT100, JPT100 300 ohms, RTB
M-6201	2 AI, Thermocouple: 30 mV(1 $\mu$ V/bit), RTB

### Analog Output Modules

Model Name	Description
M-4402	4 AOs, 4-20 mA, 12-bit, RTB
M-4410	4 AOs, voltage, 0-10 V, 12-bit, RTB

### Digital Input Modules

Model Name	Description
M-1800	8 DIs, sink, 24 VDC, RTB
M-1801	8 DIs, source, 24 VDC, RTB
M-1600	16 DIs, sink, 24 VDC, RTB
M-1601	16 DIs, source, 24 VDC, 20-pin
M-1450	4 DIs, 110 VAC, RTB
M-1451	4 DIs, 220 VAC, RTB

## Digital Output Modules

Model Name	Description
M-2800	8 DOs, sink, MOSFET, 24 VDC, 0.5 A, RTB
M-2801	8 DOs, source, MOSFET, 24 VDC, 0.5 A, RTB
M-2600	16 DOs, sink, MOSFET, 24 VDC, 0.3 A, 20-pin
M-2601	16 DOs, source, MOSFET, 24 VDC, 0.3 A, 20-pin
M-2450	4 DOs, relay, 230 VAC, 24 VDC, 2.0 A, RTB

## Power Modules

Model Name	Description
M-7001	Modular remote I/O module with 24 VDC system power input, RTB, -10 to 60°C operating temperature
M-7002	Modular remote I/O module with 5/24/48 VDC or 110/220 VAC field power input, RTB, -10 to 60°C operating temperature
M-7804	Modular remote I/O module with 8 channels 0 VDC output, RTB, -10 to 60°C operating temperature
M-7805	Modular remote I/O module with 8 channels 24 VDC output, RTB, -10 to 60°C operating temperature

## Temperature Input Modules

Model Name	Description
M-6200	Modular remote I/O module with 2 RTDs, RTB, -10 to 60°C operating temperature
M-6201	Modular remote I/O module with 2 TCs, RTB, -10 to 60°C operating temperature

# Specifications

## Adaptors

### NA-4010

#### LAN

**Ethernet:** 1 x 10/100 Mbps, RJ45

#### Software Features

**Protocols:** Modbus/TCP, HTTP, Bootp

**IP Settings:** ARP, Bootp, static IP

**Programming Library:** MXIO DLL library for Windows supporting Visual Basic, Visual C++, Borland C++ Builder, .NET

**Number of I/O Modules Supported:** Max. of 32

#### Power Requirements

**Power Input:** 11 to 28.8 VDC, 24 VDC typical

**Power Consumption:** 60 mA @ 24 VDC

**Current for I/O Modules:** Max. 1.5 A @ 5 VDC

#### MTBF (mean time between failure)

**Time:** 4,739,300 hrs

**Database:** Telcordia (Bellcore)



## NA-4020/4021

### Serial Communication Parameters

**Parity:** None, Even, Odd

**Data Bits:** 7, 8

**Stop Bits:** 1, 2

**Baudrate:** 1200 to 115200 bps

**Signals:**

- NA-4020: Data+, Data-, Gnd, DIR (5-contact terminal block)
- NA-4021: TxD, RxD, Gnd (9-pin D-Sub female)

### Software Features

**Protocols:** Modbus/RTU, Modbus/ASCII

**Modbus Address:** 00 to 99 (set by rotary switches)

**Programming Library:** MXIO DLL library for Windows; Supports Visual Basic, Visual C++, Borland C++ Builder, .net, VB/VC.NET

**Number of I/O Modules Supported:** Max. of 32

### Power Requirements

**Power Input:** 11 to 28.8 VDC, 24 VDC typical

**Power Consumption:** 70 mA @ 24 VDC

**Current for I/O Modules:** Max. 1.5 A @ 5 VDC

### MTBF (mean time between failure)

**Time:**

NA-4020: 4,695,360 hrs

NA-4021: 4,721,640 hrs

**Database:** Telcordia (Bellcore)

## Common Specifications for the NA-4010 and NA-4020/4021

### Field Power

**Rated Voltage:** 11 to 28.8 VDC, 24 VDC typical

**Current in Field Power Contact:** Max. 10 A

### Isolation

**System Power to I/O Driver:** Optical isolation

### Physical Characteristics

**Dimensions:** 45 x 99 x 70 mm (1.77 x 3.90 x 2.76 in)

**Weight:** 150 g

**Mounting:** DIN rail

### Environmental Limits

**Operating Temperature:** -10 to 60°C (14 to 140°F)

**Storage Temperature:** -40 to 85°C (-40 to 185°F)

**Ambient Relative Humidity:** 5 to 95% (non-condensing)

**Altitude:** Up to 2000 m

**Note:** Please contact Moxa if you require products guaranteed to function properly at higher altitudes.

### Standards and Certifications

**Safety:** UL 508

**EMI:** 61000-3-2; EN 61000-3-3; EN 61000-6-4; FCC Part 15, Subpart B, Class A

**EMS:** EN 61000-4-2, EN 61000-4-3, EN 61000-4-4, EN 61000-4-5, EN 61000-4-6, EN 61000-4-8, EN 61000-4-11, EN 61000-6-2

**Vibration:** IEC-68-2-6 (2 g's during operation)

### Warranty

**Warranty Period:** 2 years

**Details:** See [www.moxa.com/warranty](http://www.moxa.com/warranty)

## Analog Input Modules

### M-3802: 8 analog inputs, 4 to 20 mA, 12 bits

**Analog Inputs:** 8 channels  
**Resolution in Ranges:** 12 bits, 3.91  $\mu$ A/bit  
**Input Current Range:** 4 to 20 mA (single-ended)  
**Data Format:** 16-bit integer (2's complement)  
**Accuracy:**

- $\pm 0.1\%$ , FSR @ 25°C
- $\pm 0.3\%$ , FSR @ 0°C, 60°C

**Input Impedance:** 120 ohms  
**Conversion Time:** 4 ms for all channels  
**Power Consumption:** 80 mA @ 5 VDC  
**Isolation:** I/O to logic (photocoupler isolation)  
**Wiring:** I/O cable max. AWG14  
**MTBF:** 7,375,920 hrs (Database: Telcordia/Bellcore)

### M-3810: 8 analog inputs, 0 to 10 V, 12 bits

**Analog Inputs:** 8 channels  
**Resolution in Ranges:** 12 bits, 2.44 mV/bit  
**Input Current Range:** 0 to 10 VDC (single-ended)  
**Data Format:** 16-bit integer (2's complement)  
**Accuracy:**

- $\pm 0.1\%$ , FSR @ 25°C
- $\pm 0.3\%$ , FSR @ 0°C, 60°C

**Input Impedance:** 500K ohms  
**Conversion Time:** 4 ms for all channels  
**Power Consumption:** 60 mA @ 5 VDC  
**Isolation:** I/O to logic (photocoupler isolation)  
**Wiring:** I/O cable max. AWG14  
**MTBF:** 7,288,320 hrs (Database: Telcordia/Bellcore)

## Analog Output Modules

### M-4402: 4 analog outputs, 4 to 20 mA, 12 bits

**Analog Outputs:** 4 channels  
**Resolution in Ranges:** 12 bits, 3.91  $\mu$ A/bit  
**Output Current Range:** 4 to 20 mA (single-ended)  
**Data Format:** 16-bit integer (2's complement)  
**Accuracy:**

- $\pm 0.1\%$ , FSR @ 25°C
- $\pm 0.3\%$ , FSR @ 0°C, 60°C

**Output Impedance:** 500 ohms (max.)  
**Conversion Time:** 2 ms for all channels  
**Power Consumption:** 60 mA @ 5 VDC  
**Isolation:** I/O to logic (photocoupler isolation)  
**Wiring:** I/O cable max. AWG14  
**MTBF:** 7,840,200 hrs (Database: Telcordia/Bellcore)

## M-4410: 4 analog outputs, 0 to 10 V, 12 bits

**Analog Outputs:** 4 channels  
**Resolution in Ranges:** 12 bits, 2.44 mV/bit  
**Output Current Range:** 0 to 10 VDC (single-ended)  
**Data Format:** 16-bit integer (2's complement)  
**Accuracy:**

- $\pm 0.1\%$ , FSR @ 25°C
- $\pm 0.3\%$ , FSR @ 0°C, 60°C

**Output Impedance:** 5K ohms (max.)  
**Conversion Time:** 2 ms for all channels  
**Power Consumption:** 60 mA @ 5 VDC  
**Isolation:** I/O to logic (photocoupler isolation)  
**Wiring:** I/O cable max. AWG14  
**MTBF:** 6,219,600 hrs (Database: Telcordia/Bellcore)

## Digital Input Modules

### M-1800: 8 digital inputs, sink type, 24 VDC

**Digital Inputs:** 8 channels  
**Type:** sink  
**On-state Voltage:** 24 VDC nominal, 11 to 28.8 VDC  
**Off-state Voltage:** 0 to 5 VDC  
**On-state Current:** 6 mA/point @ 28.8 VDC (max.)  
**Input Impedance:** 5.1K ohms (typical)  
**Filtering Time:** 1.5 ms (typical)  
**Common Type:** External common (single common)  
**Power Consumption:** 35 mA @ 5 VDC  
**Isolation:** I/O to logic (photocoupler isolation)  
**Wiring:** I/O cable max. AWG14  
**MTBF:** 15,759,240 hrs (Database: Telcordia/Bellcore)

### M-1801: 8 digital inputs, source type, 24 VDC

**Digital Inputs:** 8 channels  
**Type:** source  
**On-state Voltage:** 24 VDC nominal, 11 to 28.8 VDC  
**Off-state Voltage:** 0 to 5 VDC  
**On-state Current:** 6 mA/point @ 28.8 VDC (max.)  
**Input Impedance:** 5.1K ohms (typical)  
**Filtering Time:** 1.5 ms (typical)  
**Common Type:** External common (single common)  
**Power Consumption:** 35 mA @ 5 VDC  
**Isolation:** I/O to logic (photocoupler isolation)  
**Wiring:** I/O cable max. AWG14  
**MTBF:** 15,811,800 hrs (Database: Telcordia/Bellcore)

## M-1600: 16 digital inputs, sink type, 24 VDC

**Digital Inputs:** 16 channels  
**Type:** sink  
**On-state Voltage:** 24 VDC nominal, 11 to 28.8 VDC  
**Off-state Voltage:** 0 to 5 VDC  
**On-state Current:** 6 mA/point @ 28.8 VDC (max.)  
**Input Impedance:** 5.1K ohms (typical)  
**Filtering Time:** 1.5 ms (typical)  
**Common Type:** 16 channels for 2 COMs (single common)  
**Power Consumption:** 40 mA @ 5 VDC  
**Isolation:** I/O to logic (photocoupler isolation)  
**Wiring:** I/O flat cable 20-pin  
**MTBF:** 11,659,560 hrs (Database: Telcordia/Bellcore)

## M-1601: 16 digital inputs, source type, 24 VDC

**Digital Inputs:** 16 channels  
**Type:** source  
**On-state Voltage:** 24 VDC nominal, 11 to 28.8 VDC  
**Off-state Voltage:** 0 to 5 VDC  
**On-state Current:** 6 mA/point @ 28.8 VDC (max.)  
**Input Impedance:** 5.1K ohms (typical)  
**Filtering Time:** 1.5 ms (typical)  
**Common Type:** 16 channels for 2 COMs (single common)  
**Power Consumption:** 40 mA @ 5 VDC  
**Isolation:** I/O to logic (photocoupler isolation)  
**Wiring:** I/O flat cable 20-pin  
**MTBF:** 11,694,600 hrs (Database: Telcordia/Bellcore)

## M-1450: 4 digital inputs, 110 VAC

**Digital Inputs:** 4 channels, 110 VAC  
**On-state Voltage:** 120 VAC nominal, 85 to 132 VAC  
**Off-state Voltage:** 0 to 45 VAC  
**On-state Current:** 8 mA/point @ 132 VAC (max.)  
**Input Impedance:** 11K ohms (typical)  
**Common Type:** 4 channels for 2 COMs (single common)  
**Power Consumption:** 35 mA @ 5 VDC  
**Isolation:** I/O to logic (photocoupler isolation)  
**Wiring:** I/O cable max. AWG14  
**MTBF:** 19,482,240 hrs (Database: Telcordia/Bellcore)

## M-1451: 4 digital inputs, 220 VAC

**Digital Inputs:** 4 channels, 220 VAC  
**On-state Voltage:** 240 VAC nominal, 170 to 264 VAC  
**Off-state Voltage:** 0 to 45 VAC  
**On-state Current:** 12 mA/point @ 264 VAC (max.)  
**Input Impedance:** 22K ohms (typical)  
**Common Type:** 4 channels for 2 COMs (single common)  
**Power Consumption:** 35 mA @ 5 VDC  
**Isolation:** I/O to logic (photocoupler isolation)  
**Wiring:** I/O cable max. AWG14  
**MTBF:** 19,727,520 hrs (Database: Telcordia/Bellcore)

## Digital Output Modules

### M-2800: 8 digital outputs, sink type, 24 VDC, 0.5 A

**Digital Outputs:** 8 channels  
**Type:** sink  
**Output Range:** 24 VDC nominal  
**On-state Voltage Drop:** 0.3 VDC @ 25°C (max.)  
**On-state Current:** 1 mA per channel (min.)  
**Off Leakage Current:** 50 µA (max.)  
**Current Rating:** 0.5 A per channel  
**Common Type:** 8 channels per external common (single common)  
**Power Consumption:** 60 mA @ 5 VDC  
**Isolation:** I/O to logic (photocoupler isolation)  
**Wiring:** I/O cable max. AWG14  
**MTBF:** 13,884,600 hrs (Database: Telcordia/Bellcore)

### M-2801: 8 digital outputs, source type, 24 VDC, 0.5 A

**Digital Outputs:** 8 channels  
**Type:** source  
**Output Range:** 24 VDC nominal  
**On-state Voltage Drop:** 0.3 VDC @ 25°C (max.)  
**On-state Current:** 1 mA per channel (min.)  
**Off Leakage Current:** 50 µA (max.)  
**Current Rating:** 0.5 A per channel  
**Common Type:** 8 channels per external common (single common)  
**Power Consumption:** 60 mA @ 5 VDC  
**Isolation:** I/O to logic (photocoupler isolation)  
**Wiring:** I/O cable max. AWG14  
**MTBF:** 14,340,120 hrs (Database: Telcordia/Bellcore)

## M-2600: 16 digital outputs, sink type, 24 VDC, 0.3 A

**Digital Outputs:** 16 channels

**Type:** sink

**Output Range:** 24 VDC nominal

**On-state Voltage Drop:** 0.3 VDC @ 25°C (max.)

**On-state Current:** 1 mA per channel (min.)

**Off Leakage Current:** 50 µA (max.)

**Current Rating:** 0.5 A per channel

**Common Type:** 8 channels per external common (single common)

**Power Consumption:** 60 mA @ 5 VDC

**Isolation:** I/O to logic (photocoupler isolation)

**Wiring:** I/O flat cable 20-pin

**MTBF:** 9,732,360 hrs (Database: Telcordia/Bellcore)

## M-2601: 16 digital outputs, source type, 24 VDC, 0.3 A

**Digital Outputs:** 16 channels

**Type:** source

**Output Range:** 24 VDC nominal

**On-state Voltage Drop:** 0.3 VDC @ 25°C (max.)

**On-state Current:** 1 mA per channel (min.)

**Off Leakage Current:** 50 µA (max.)

**Current Rating:** 0.5 A per channel

**Common Type:** 8 channels per external common (single common)

**Power Consumption:** 60 mA @ 5 VDC

**Isolation:** I/O to logic (photocoupler isolation)

**Wiring:** I/O flat cable 20-pin

**MTBF:** 9,749,880 hrs (Database: Telcordia/Bellcore)

## M-2450: 4 relay outputs, 24-VDC/230-VAC, 2 A

**Relay Outputs:** 4 channels

**Relay Type:**

- Form A (N.O.)
- Single Pole, Single Throw (SPST)

**Output Voltage Range:** Load dependent

- 5 to 28.8 VDC @ 2 A resistive
- 48 VDC @ 0.8 A resistive
- 110 VDC @ 0.3 A resistive
- 250 VAC @ 2 A resistive

**Output Current Rating:** At rated power

- 2 A @ 5 to 28.8 VDC
- 0.8 A @ 48 VDC
- 0.5 A @ 110 VDC
- 2 A @ 250 VAC

**Min. Load:** 100 µA, 100 m VDC per point

**Max. On-state Voltage Drop:** 0.5 V @ 2 A, resistive load, 24 VDC

**Off-state Leakage Current:** 1.5 mA (max)

**Common Type:** 1 channel for 1 COM

**Power Consumption:** 65 mA @ 5 VDC

**Isolation:** I/O to logic (Relay Coil/Contact isolation)

**Wiring:** I/O cable max. AWG14

**MTBF:** 14,033,520 hrs (Database: Telcordia/Bellcore)

## Power Modules

### M-7001: System power module

**System Input Voltage:** 24 VDC, 11 to 28.8 VDC  
**Field Power Input Voltage:** 24 VDC ( $\pm 20\%$ )  
**Current for I/O Modules:** 1.5 A @ 5 VDC (Max.)  
**System Bus Output Voltage:** 5 VDC (Max.)  
**Field Power Contacts Current:** 10 A (Max.)  
**MTBF:** 19,569,840 hrs (Database: Telcordia/Bellcore)

### M-7002: Field power module

**Field Power Input Voltage:**

- DC: 5 VDC, 24 VDC, 48 VDC
- AC: 110 VAC, 220 VAC

**Current for Field Power Contacts:** 10 A (Max.)  
**MTBF:** 75,528,720 hrs (Database: Telcordia/Bellcore)

### M-7804: 0 VDC

**Channels:** 8  
**Mode:** 0 VDC  
**MTBF:** 73,750,440 hrs (Database: Telcordia/Bellcore)

### M-7805: 24 VDC

**Channels:** 8  
**Mode:** 24 VDC  
**MTBF:** 73,750,440 hrs (Database: Telcordia/Bellcore)

## Temperature Input Modules

### M-6200: 2 analog inputs, RTD: PT100, JPT100

**RTD Inputs:** 2 channels

**Sensor Types:**

- PT50, PT100, PT200, PT500, PT1000 (resistance 100 milli-ohms/bit)
- JPT100, JPT200, JPT500, JPT1000 (resistance 10 milli-ohms/bit)
- NI100, NI200, NI500, NI1000, NI120, CU10 (resistance 20 milli-ohms/bit)

**Resolution:** 0.1°C/10 milli-ohms

**Data Format:** 16-bit integer (2's complement)

**Accuracy:**

- ±0.1%, FSR @ 25°C
- ±0.3%, FSR @ 0°C, 60°C

**Input Impedance:** 500K ohms

**Conversion Time:** 200 ms for all channels

**Diagnostics:** Range over (if range over, data=Dx8000)

**Power Consumption:** 80 mA @ 5 VDC

**Isolation:** I/O to logic (photocoupler isolation)

**Wiring:** I/O cable max. AWG14

**MTBF:** 3,644,160 hrs (Database: Telcordia/Bellcore)

### M-6201: 2 analog inputs, thermocouple

**Thermocouple Inputs:** 2 channels

**Sensor Types:**

Type J/K/T/E/R/S/B/N/L/U/C/D

(mV input 10 µV/bit, 2 µV/bit)

**Resolution:** 0.1°C/10 µV

**Data Format:** 16-bit integer (2's complement)

**Accuracy:**

- ±0.1%, FSR @ 25°C
- ±0.3%, FSR @ 0°C, 60°C

**Input Impedance:** 500K ohms

**Conversion Time:** 200 ms for all channels

**Diagnostics:** Range over (if range over, data=Dx8000)

**Power Consumption:** 80 mA @ 5 VDC

**Isolation:** I/O to logic (photocoupler isolation)

**Wiring:** I/O cable max. AWG14

**MTBF:** 3,828,120 hrs (Database: Telcordia/Bellcore)



# Hardware Installation

---

This chapter includes information about installing the ioLogik 4000 I/O server, including the Ethernet network adaptors and RS-485, RS-232 network adaptors.

The following topics are covered in this chapter:

- ❑ **System Architecture**
- ❑ **Connecting the Network Adaptor to I/O Modules**
  - Appearance
  - Installing I/O Modules on a DIN Rail
  - Removing I/O Modules from a DIN Rail
  - Installing an RTB (Removable Terminal Block)
- ❑ **Connecting the Power System**
- ❑ **Connecting to the Network**
  - NA-4010 Ethernet Network Adaptor
  - NA-4020 RS-485 Network Adaptor
  - NA-4021 RS-232 Network Adaptor
- ❑ **LED Indicators**
  - LED Indicators for Network Adaptors
  - LED Indicators for I/O Modules
- ❑ **When to Use the Power Expansion Module**
- ❑ **When to Use the Field Power Distributor**
- ❑ **When to Use the Potential Distributor**
- ❑ **Safety Notes**
  - Installation and Cabling Precautions
  - Operating Precautions

# System Architecture

- The ioLogik 4000 slice-type I/O server consists of a network adaptor that supports Ethernet, RS-485, or RS-232, and up to 32 I/O modules.
- The ioLogik 4000's network adaptor is the brains of the system. Its responsibility is to collect information from each I/O module, and determine the parameters for the I/O module's operation. Communication between the Network adaptor and I/O modules is achieved by a system communication bus.
- Modbus Addresses for each I/O channel are arranged dynamically by the network adaptor, based on the installed I/O modules.
- The network adaptor requires two sets of 24 VDC power inputs. One is for the internal logic circuit, and the other is for the field I/O circuits.
- The network adaptor provides 5 VDC power to all connected I/O modules. When the total current consumption of the I/O modules exceeds 1.5 A, you will need to insert an extra power expansion module. To determine how many power expansion modules are required, refer to the spreadsheet in **Start → Program Files → ioLogik-Utility**.

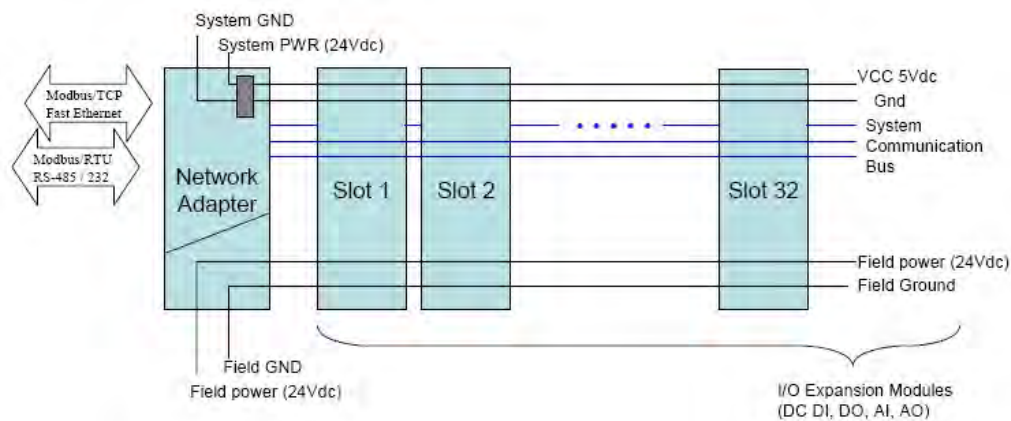

# Connecting the Network Adaptor to I/O Modules

This section describes how to install ioLogik 4000 I/O modules with the network adaptor.

## Appearance

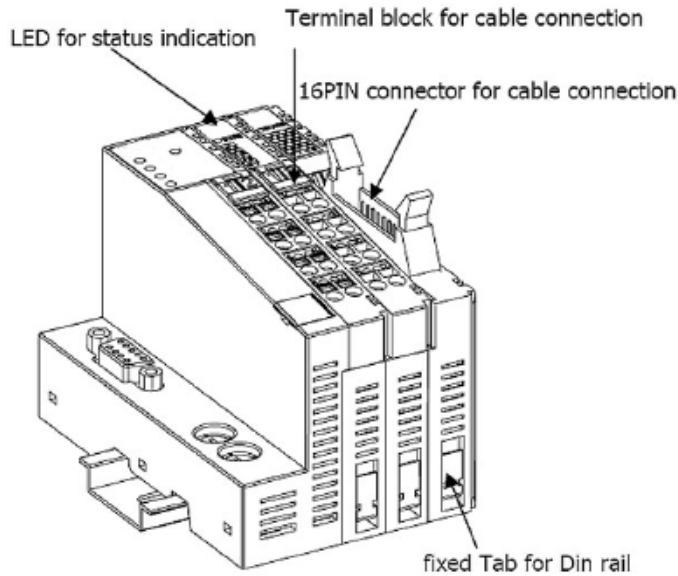

## Installing I/O Modules on a DIN Rail

**Step 1:** Align the I/O module and network adaptor side by side, making sure the upper and lower rails are hooked.

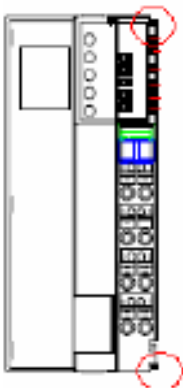

**Step 2:** Push the I/O module along the inner rail until it touches the DIN rail, and then push hard to clip it onto the DIN rail.

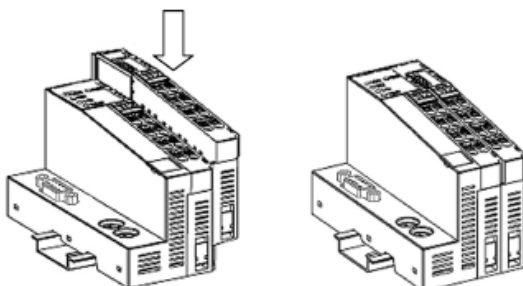

## Removing I/O Modules from a DIN Rail

**Step 1:** Use your finger or a screw driver to push down the tab located on the lower part of the module.

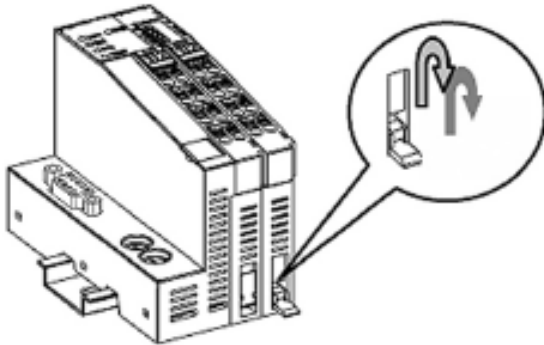

**Step 2:** Pull out the I/O module.

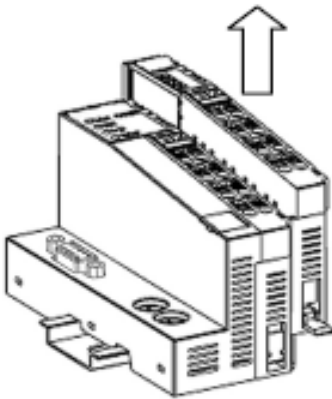

## Installing an RTB (Removable Terminal Block)

### Removing the RTB from the I/O Module

Pull hard to remove the plastic belt from the RTB.

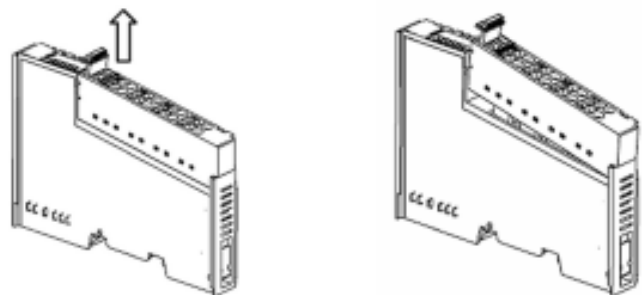

## Installing the RTB on the I/O Module

Align the lower part of the terminal block with the I/O module, and then push the RTB so that it fits into the I/O module.

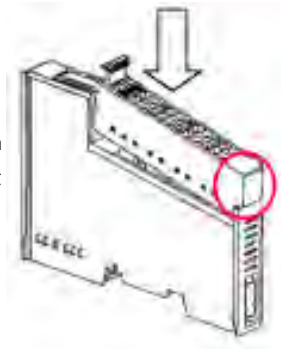

## Connecting the Power System

Two 24 VDC power sources are required to power the ioLogik 4000. One 24 VDC power input is for system power, and the other 24 VDC power input is for the field I/Os. For field installation, system power and field power are provided by different power supply systems.

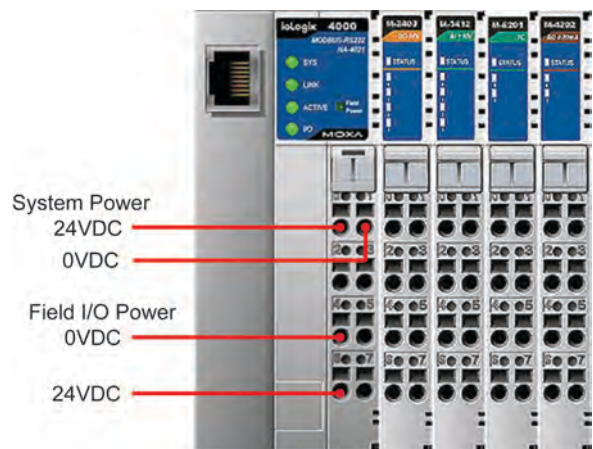

## Connecting to the Network

### NA-4010 Ethernet Network Adaptor

The NA-4010 Ethernet network adaptor supports standard 10/100 Mbps Ethernet. For first time users, we recommend that you link from your host computer to the NA-4010 over a local Ethernet network to handle IP and system configuration. Once the installation is done, you may move the Ethernet I/O system to the field.

### Connecting a Single Ethernet I/O Server



**ioLogik 4000  
Slice I/O server  
E.g., IP = 192.168.8.1, Port = 502**

### Ethernet Pin Assignments

Pin	Signal
1	Tx+
2	Tx-
3	Rx+
6	Rx-

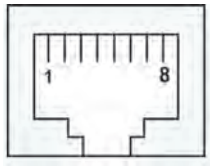

### NA-4020 RS-485 Network Adaptor

To configure the NA-4020 for the first time, we recommend connecting the NA-4020 to a host computer running the ioAdmin utility. Once the I/O system is configured, you can move the entire system to the field.

### Connecting a Single Serial I/O Server

RS-485 or RS-232



E.g., COM1  
9600, N, 8, 1

ioLogik \$000  
Slic I/O Server  
E.g., ID = 10

### NA-4020 RS-485 Port Pin Assignment

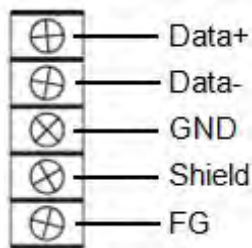

## NA-4021 RS-232 Network Adaptor

To configure the NA-4020 for the first time, connect the NA-4020 to a host computer running the ioAdmin utility.

### NA-4021 RS-232 Port Pin Assignment

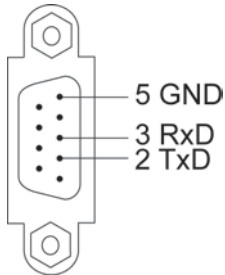

## LED Indicators

This section describes the ioLogik 4000 system's LED indicators.

### LED Indicators for Network Adaptors

#### NA-4010

LED Name	LED Color	LED Function
SYS	Off	No power.
	Green	Steady On: Operating condition normal.
	Red/Green	Toggling: Modbus error (e.g., watch dog timer error)
	Red	Steady On: EEPROM checksum error. Flashing: Memory error or CPU watchdog error. Note: Please contact your vendor for assistance.
LINK	Green	Ethernet connected.
ACTIVE	Green	Flashing: Transmitting or Receiving data over Ethernet.
I/O	Off	No I/O module detected.
	Green	Steady On: System bus to I/O modules is running normally. Flashing: System bus to I/O modules ready, but the network adaptor is not exchanging data with I/O modules.
	Red	Steady On: System bus communication failure. Flashing: One or more I/O modules are in an error state. Note: The following situations may cause a red I/O LED. a. I/O module plugged in during operation. b. I/O module not firmly locked on the rail. c. One of the modules is damaged.
Field Power	Off	24 VDC field power is not connected
	Green	24 VDC field power detected

## NA-4020/4021

LED Name	LED Color	LED Function
SYS	Off	No power.
	Green	Steady On: Operating condition normal.
	Red/Green	Toggling: Modbus error (e.g., watch dog timer error)
	Red	Steady On: EEPROM checksum error. Flashing: Memory error or CPU watchdog error. Note: Please contact your vendor for assistance.
RxD	Off	No power or communication.
	Green	Flashing: Receiving data from the serial port.
TxD	Off	No power or communication.
	Green	Flashing: Sending data to the serial port.
I/O	Off	No I/O module detected.
	Green	Steady On: System bus to I/O modules is running normally. Flashing: System bus to I/O modules ready, but the network adaptor is not exchanging data with I/O modules.
	Red	Steady On: System bus communication failure. Flashing: One or more I/O modules are in an error state. Note: The following situations may cause a red I/O LED. a. I/O module plugged in during operation. b. I/O module not firmly locked on the rail. c. One of the modules is damaged.
Field Power	Off	No 24 VDC field power
	Green	24 VDC field power detected

## LED Indicators for I/O Modules

Each DIO or AIO module is equipped with a Module Status LED indicating operation status.

LED Name	LED Color	LED Function
Status	Off	Not powered on during initialization.
	Green	Steady On: System ready. Flashing: I/O module ready for communication.
	Red	Steady On: I/O module hardware problem. Flashing: System bus communication error.

Each DIO or AIO channel is equipped with Channel Status LEDs. Refer to Chapter 4 for more information.



## When to Use the Power Expansion Module

When the total current consumption for connected I/O modules exceeds 1.5 A, an M-7001 power expansion module is required.

Refer to the "Power Consumption Spreadsheet" in **Program Files → ioLogik → Utility** to calculate if an extra power expansion module is needed. The spreadsheet requires Microsoft Excel to operate. Once you enter the I/O module quantity, the required number of power expansion modules will be computed automatically.

After installing additional power expansion modules, restart the system in the following sequence to ensure a proper start-up.

### Power Off Sequence

1. Unplug the network adaptor's terminal block.
2. Unplug the expansion module's terminal block.

### Power Up Sequence

1. Plug in the power expansion module's terminal block.
2. Plug in the network adaptor's terminal block.

## When to Use the Field Power Distributor

Most of the field power DIO/AIO modules for the ioLogik 4000 series are 24 VDC. If you need to connect 48 VDC or 110 VAC, 230 VAC digital input or output modules, you must use the Field Power Distributor to isolate different field powers within a single ioLogik 4000 system.

If all of the DIO modules are 110 VAC, you will need at least one field power distributor to isolate the field power from the network adaptor (likewise when using 48 VDC or 230 VAC).

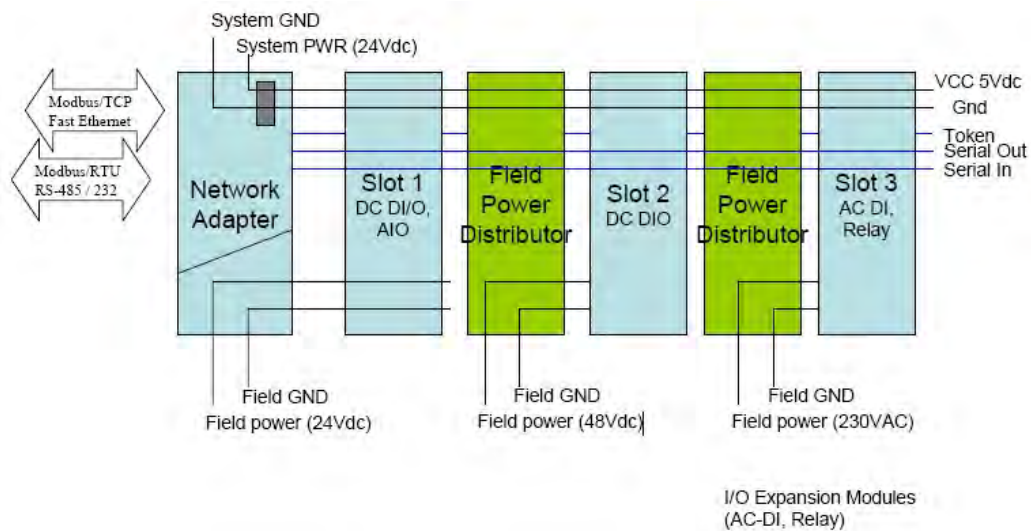

## When to Use the Potential Distributor

Three types of potential distributor module provide extra wiring points, such as shielding ground, field power 0 V, and field power 24 V.

For example, the 8-channel digital input (sink type) module itself does not have a 24 V wiring point, but you can add a 24 V potential distributor to make wiring easier.

# Safety Notes

## Installation and Cabling Precautions

- Check the rated voltage and current for the products before wiring.
- Use the rated power supply and specified cables. Using the wrong power supply could cause a fire.
- Cabling should be done by a certified electrician according to the Electricity Engineering Regulations.
- Improper cabling could cause a fire, or electric shock.

## Operating Precautions

- Do not touch the terminal when the power is on to avoid electric shock.
- Do not assemble the product when the power is on.
- Do not modify the wiring while operating the product.
- Pay attention to the power linkage procedure. An incorrect process flow could lead to mechanical damage or other hazards.

**ATTENTION**

The End Module should be covered in to prevent unexpected damage from exposure of the data pin.

## Getting Started

---

In this chapter, we illustrate how to configure the ioLogik 4000 Ethernet I/O system and ioLogik 4000 RS-485/232 I/O system.

The following topics are covered in this chapter:

### ❑ **Installing ioAdmin Utility**

#### ❑ **Configuring the NA-4010 Ethernet I/O System**

- Initializing the IP Address
- Linking the Ethernet I/O System to ioAdmin
- Password Protection
- Reset to Default
- System Restart
- Deleting an I/O Server from the List
- Network
- TCP Socket Timeout Interval
- Watchdog Timer
- Firmware Upgrade
- Exporting the System Configuration
- Remote Monitoring
- I/O Status Refresh Rate

#### ❑ **Checking the Ethernet I/O Status via Web Browser (NA-4010 only)**

#### ❑ **Configuring the NA-4020/4021's RS-485/232 I/O System**

- Configuring Communication Parameters
- Linking the RS-485/232 I/O Server to ioAdmin
- Password Protection
- Reset to Default
- Restarting the System
- Deleting an I/O Server from the List
- Watchdog Timer
- Firmware Update
- I/O Status Refresh Rate

#### ❑ **Modbus Address Mapping**

- Finding a Modbus Address for I/O Channels
- Exporting Modbus Address Settings

## Installing ioAdmin Utility

Insert the CD-ROM from the network adaptor package into the host computer. Run **SETUP.EXE**, which is located in the root directory. The installation program will guide you through the installation process and install the ioAdmin utility along with the MXIO DLL library.

After the installation is done, run ioAdmin from **Start → Program Files → Moxa → IO Server → Utility → ioAdmin**.

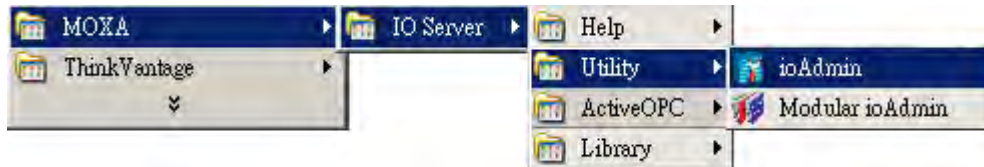

## Configuring the NA-4010 Ethernet I/O System

### Initializing the IP Address

1. Check the MAC Address, which is located on the label on the left side of the network adaptor. You may use it to reconfigure the IP address at a later time.
2. Determine whether your ioLogik 4000 needs to use a static IP or dynamic IP (BOOTP application).
3. *If the ioLogik 4000 is used in a static IP environment, you can use ioAdmin to configure the new IP address. The factory default IP address is 192.168.127.254.*
4. *If the ioLogik 4000 is used in a dynamic IP environment, you can use ioAdmin to make sure BOOTP is enabled. The factory default for BOOTP is **enabled**.*



#### ATTENTION

Consult your network administrator if you do not know how to reserve a fixed IP address for your ioLogik 4000 in the MAC-IP mapping table when using a BOOTP Server. For most applications, you should assign a fixed IP address to the ioLogik 4000.

5. To set a new IP address for an Ethernet I/O server, run ioAdmin, and then click on **Reset NA 4010 Network Adaptor IP**.

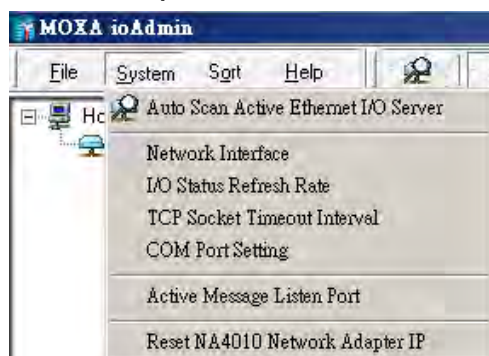

Enter the MAC Address of the NA-4010, and the new IP address. To complete the configuration, click on **Reset**.

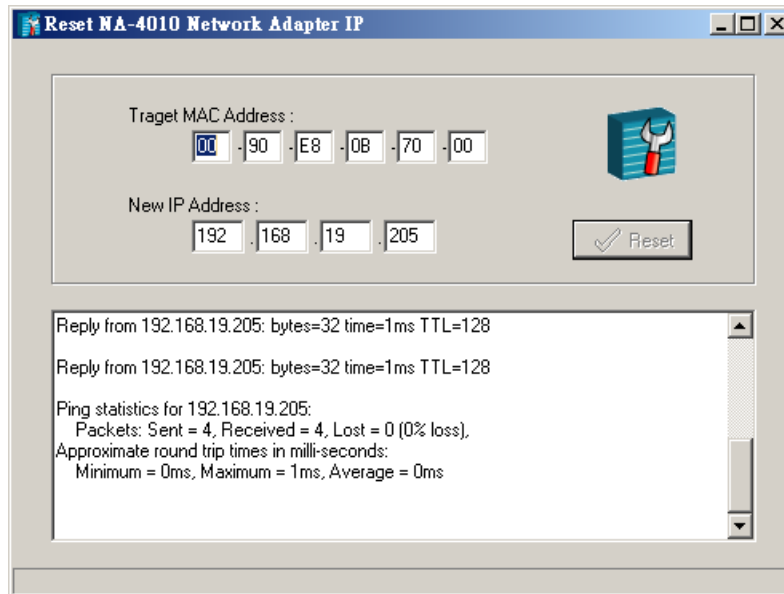

ioAdmin automatically changes the IP address and tests the new IP.

- If ioAdmin is not installed on your host computer, you may use the ARP command manually to set a new IP address for the NA-4010. Note that this approach only applies when the host computer and the Ethernet network adaptor are on the same subnet. For first time users, the default IP is 192.168.127.254. For first time installation, type the following commands at the Windows DOS prompt.

**Note:** The MAC address is printed on the left side of the Ethernet network adaptor.

```
>ping 192.168.123.236 //current IP address
>arp -a //view Ethernet physical address
>arp -d 192.168.123.236 //delete arp table
>arp -s 192.168.123.237 10-00-00-10-00-00 //assign static arp table with new IP address
>ping -n 1 -l 741 192.168.123.237 //assign new IP address
>arp -d * //clear all arp tables
>ping 192.168.123.237 //check response of adaptor's new IP address
```

After the IP address is set up using ARP, the IP address, subnet mask, and gateway should be:

IP Address = 192.168.123.237  
 Subnet Mast = 255.255.255.0  
 Gateway = 192.168.123.254

## Linking the Ethernet I/O System to ioAdmin

Before using ioAdmin to link to the Ethernet I/O system, make sure the Ethernet connection for both the I/O server and host computer are working normally. You should also make sure that the power to the I/O server is on.

There are two ways to use ioAdmin to link to the Ethernet I/O server: (1) Auto Search, and (2) Manually enter the IP address.

### Auto Search

1. To start the Auto Search function, click on **Auto Scan Module(s)** under **System**.

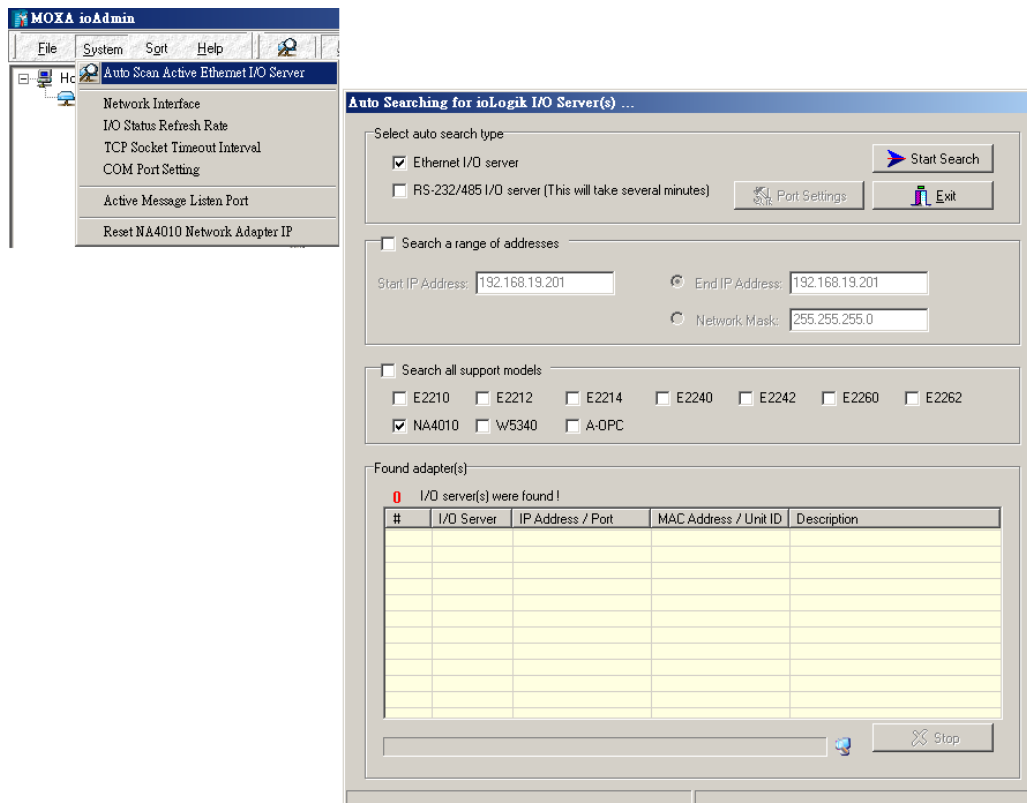

2. Select **Ethernet adaptor**, and then click on **Start Search**. ioAdmin will start searching for installed NA-4010's on the network.
3. The Auto Search function can only find Ethernet I/O Servers that are on the same subnet. To connect to Ethernet I/O Servers outside the subnet, you will need to add the Ethernet I/O server manually.

### Manually enter the IP address

1. To input the Network Adaptor's IP address manually, click the **right mouse key**, and then click on **ioLogik** in the left ioAdmin frame.



- Click on NA-4010, and then enter the IP address.

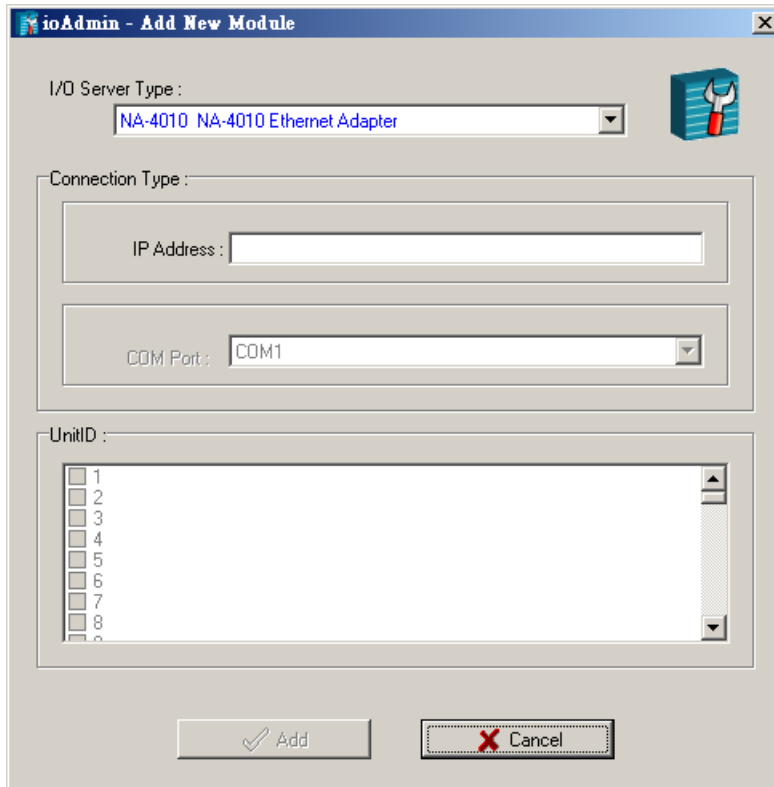

- After using auto search, or keying in the ioAdmin IP address manually, the Ethernet I/O servers that were located will appear as follows.

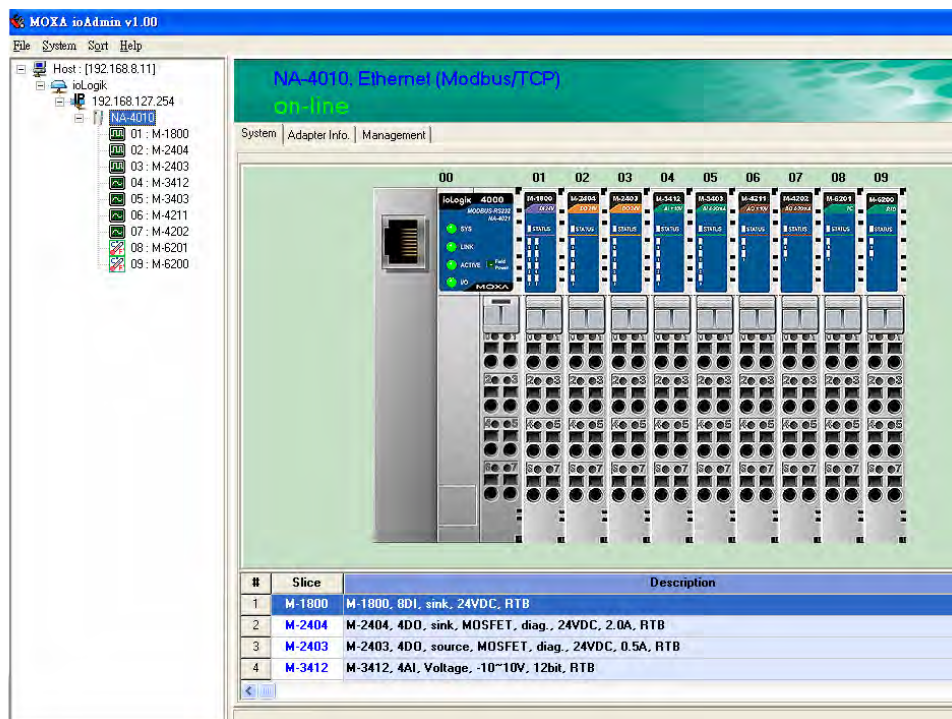

The left frame of ioAdmin shows the I/O Servers connected to the network that were located by the search process. The upper right frame indicates the combination of all I/O modules by slot number. The lower right frame lists detailed information for installed I/O modules. If you move the mouse cursor over any of the I/O modules, the model name and description will be displayed automatically.

At this point, your Ethernet I/O system should be up and running. The next section explains additional ioLogik 4000 management issues. You may also jump to Chapter 4 and check the status for each I/O channel.

## Password Protection

Network configuration, Firmware Upgrade, Watchdog configuration, Reset to Default, and Restart System can all be protected by a password to prevent unauthorized access.

The password is **blank** by default. If you have not configured a password, click on **Login** to display the firmware upgrade, network configuration, and watchdog configuration tabs.

NA-4010, Ethernet (Modbus/TCP)  
on-line

System | Adapter Info. | Management

Password for entry :  
 Login Logout

Management Setting

Change Password (8 char max.):

Reconfirm Password :  
 Update

NA-4010, Ethernet (Modbus/TCP)  
on-line

System | Adapter Info. | Management | Network | Firmware Upgrade | Watchdog

Password for entry :  
 Login Logout

Management Setting

Change Password (8 char max.):

Reconfirm Password :  
 Update

## Reset to Default

The Network Adaptor settings, including IP address, netmask, gateway, watchdog timer, I/O module safety status, and temperature sensor parameters are stored in the network adaptor.

### How to Reset to Default

Right click on the target I/O server, and then click on **Reset to Default**. You may need to wait 10 seconds or longer for the process to finish. ioAdmin will reconnect the I/O Server automatically.

**NOTE** This function requires password authorization to activate.



## NA-4010 Ethernet Network Adaptor Default Values

Bootp	on
ARP	on
IP	192.168.127.254
Network mask	255.255.0.0
Gateway	(Empty)
Modbus watchdog	disabled
Watchdog timeout	60 sec (120 x 0.5sec)
Password	(Empty)

## System Restart

In general, you do not need to restart the I/O server when changing I/O module configurations. However, when the I/O server indicates an I/O error, you may use this function to restart the I/O server system remotely.

**Right click** on the target I/O server, and then click on Restart System to proceed. You may need to wait 10 seconds or longer. ioAdmin will reconnect the I/O server automatically.

Note that this function requires password authorization to activate.

## Deleting an I/O Server from the List

When several I/O servers appear in ioAdmin's left frame, you can delete I/O servers from the list to make your management task easier.

**Right click** on the target I/O server and then press **Disconnect**. **Right click** on the target I/O server and then press **Delete I/O Server**. The target I/O Server will be removed from the list.

**NOTE** The ioLogik must first be disconnected to use this function.

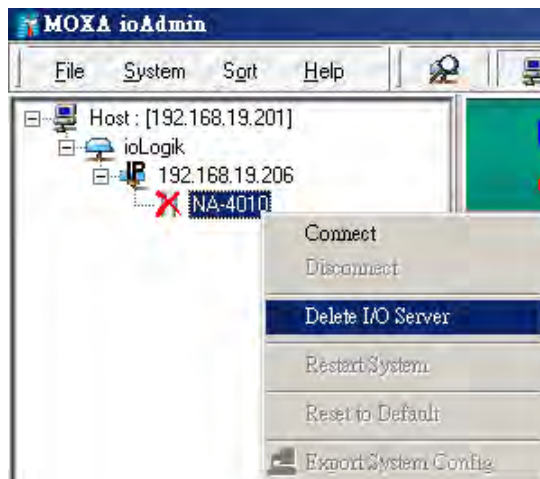

## Network

Click on the network adaptor's **Network** tab to change the IP Address, Network Mask, Gateway, and MAC address. There are two options for IP configuration: **Bootp** and **ARP**. We strongly recommend that you leave **ARP ON** to reserve the opportunity to modify the IP address when necessary.

The option **Enable Modbus/TCP idle connection timeout interval**: is used to determine the time interval needed for the Ethernet network adaptor to disconnect the Modbus/TCP connection automatically when the

host computer didn't send any packets via the Ethernet network. When the value is "0," the Ethernet network adaptor remains connected unless the host computer actively disconnects the Modbus/TCP.

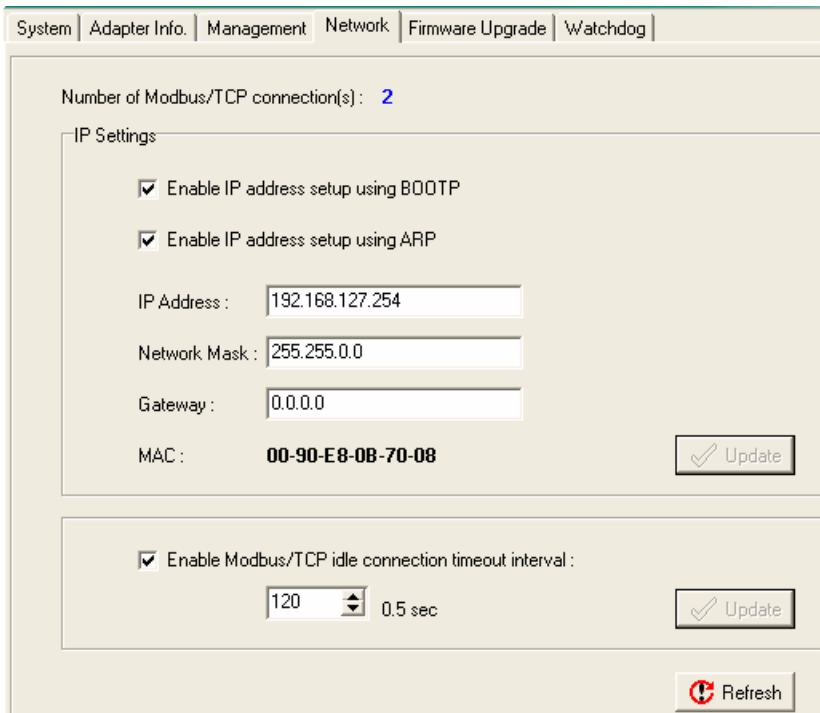

## TCP Socket Timeout Interval

The **Socket timeout interval** in the **System** menu is used to configure the timeout for each Modbus/TCP query from the host computer to the Ethernet network adaptor. The unit is seconds.

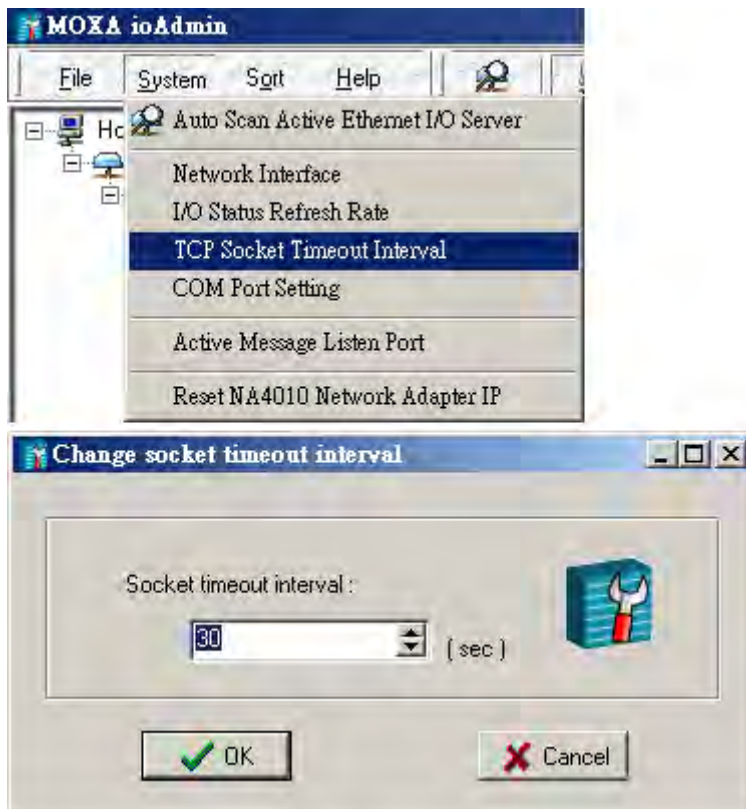

## Watchdog Timer

The Watchdog timer function is used to monitor the Modbus/TCP connection between the Ethernet Network adaptor and the host computer. The default is “off.”

When there are no queries from the host computer over a preset time interval (in 100 msec increments), the Ethernet network adaptor sets all digital output and analog output values to a predefined Safe Status. The maximum Timeout Value is 65535, which equals 6553.5 seconds.

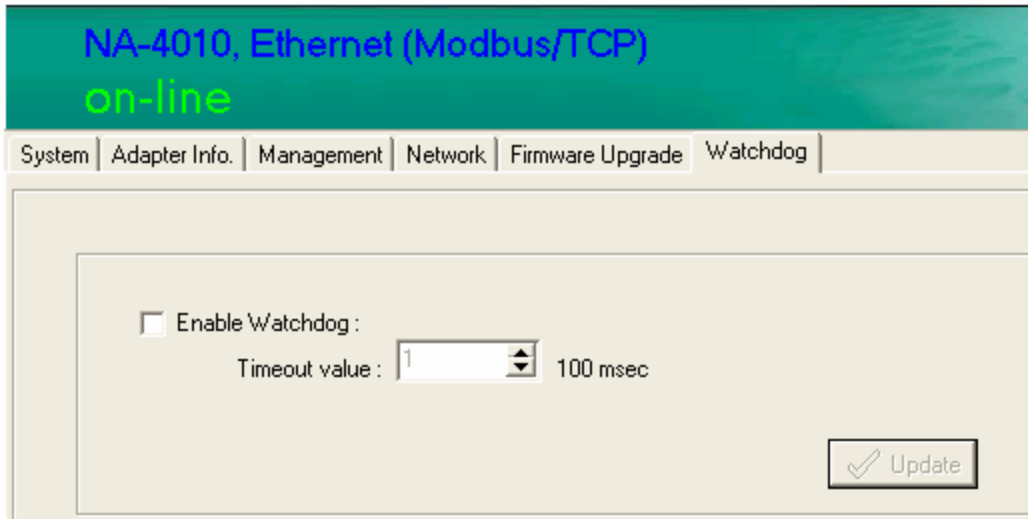

## Firmware Upgrade

The NA-4010's firmware can be updated via Ethernet. To upgrade the firmware, click the **Firmware Upgrade** tab.

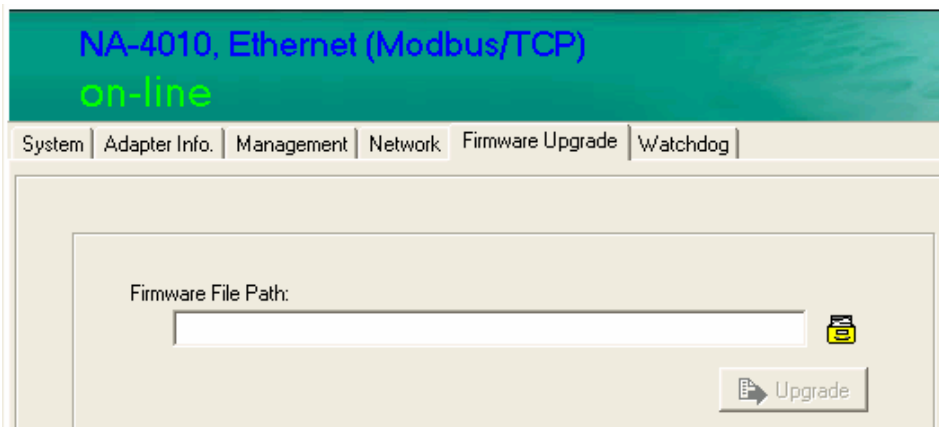

Click on the file icon and select the firmware. Press **Upgrade** when you're ready. During the firmware upgrade, DO NOT turn the ioLogik 4000's power off.

## Exporting the System Configuration

To help you record the I/O module combination and parameters, ioAdmin can generate a text report file that can help you manage the system.

The report consists of the following parts.

1. Date, Time, and Firmware version
2. Slice Models
3. Slice Configuration
4. Modbus address table

## Remote Monitoring

The NA-4010 Ethernet network adaptor allows up to 8 concurrent TCP connections, which allows ioAdmin to monitor the status of the Ethernet I/O server, even when it is operating.

## I/O Status Refresh Rate

This parameter determines how often the ioAdmin utility polls connected I/O servers. The default value is 50 (500 msec). To change the configuration, click **I/O Status Refresh Rate** under the **System** menu, and then adjust the data refresh rate. Note that the unit is in 10 msec increments, so if you enter 50, the refresh rate will be 0.5 sec.

## Checking the Ethernet I/O Status via Web Browser (NA-4010 only)

The NA-4010 Ethernet network adaptor can be used to view the adaptor's basic configuration settings.

Enter the IP address of the Ethernet I/O server in Internet Explorer's address box to access the NA-4010's browser interface. The network configuration status and firmware number can be viewed on the adaptor's homepage (see the following figure). Click the **Expansion Module** link to view information for connected modules.

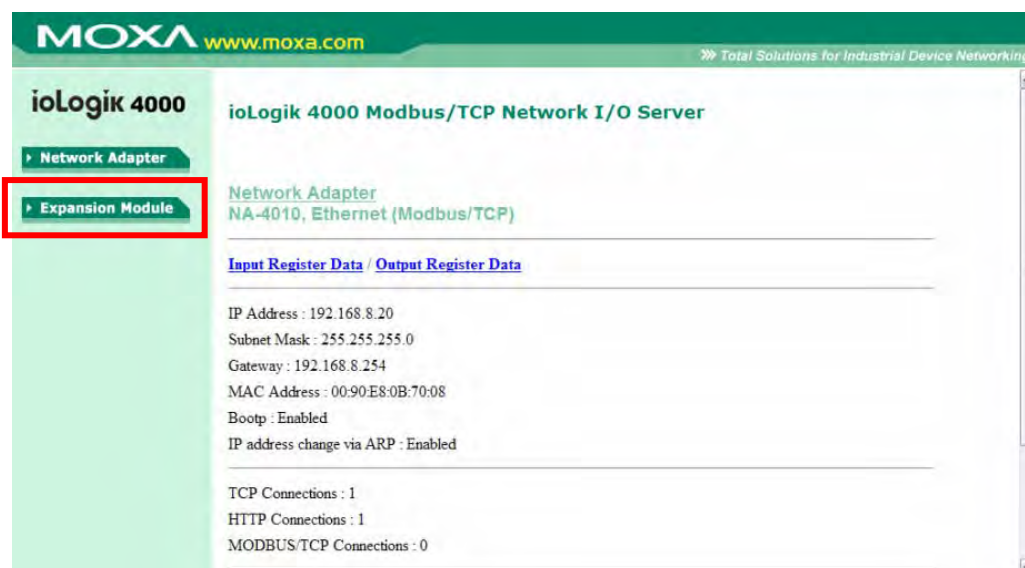

Click on a slot number to view the status of the module installed in that slot.

The screenshot shows the Moxa website header with the logo and tagline "Total Solutions for Industrial Device Networking". The main content area is titled "ioLogik 4000 Modbus/TCP Network I/O Server". On the left, there is a navigation menu with "Network Adapter" and "Expansion Module" options. The "Network Adapter" section is active, displaying the model "NA-4010, Ethernet (Modbus/TCP)". Below this, a list of modules is shown, each with a slot number and its specifications:

- Slot#1: M-1800, 8DI, sink, 24VDC, RTB
- Slot#2: M-2404, 4DO, sink, MOSFET, diag., 24VDC, 2.0A, RTB
- Slot#3: M-2403, 4DO, source, MOSFET, diag., 24VDC, 0.5A, RTB
- Slot#4: M-3412, 4AI, Voltage, -10~10V, 12bit, RTB
- Slot#5: M-3403, 4AI, Current, 4~20mA, 14bit, RTB
- Slot#6: M-4211, 2AO, Voltage, -10~10V, 12bit, RTB
- Slot#7: M-4202, 2AO, 4~20mA, 12bit, RTB
- Slot#8: M-6201, 2AI, Thermocouple:30mV(1uV/bit), RTB
- Slot#9: M-6200, 2AI, RTD:PT100,JPT100 300Ohm, RTB

The following example shows the status of a thermocouple module.

This screenshot shows the same Moxa website interface, but with the "Expansion Module" option selected in the navigation menu. The main content area displays the status for "Slot#8", which is a thermocouple module (M-6201, 2AI, Thermocouple:30mV(1uV/bit), RTB). Below the module name, the following configuration and data are shown:

- Configuration Parameter Data[Hex] = 00 10
- Input Data[Hex] = 012C 0136
- Sensor Type : K
- Temperature unit : Celsius
- Temperature Ch0 : 30.0
- Temperature Ch1 : 31.0

At the bottom of the module status section, there are links for "Prev Slot" and "Next Slot".

# Configuring the NA-4020/4021's RS-485/232 I/O System

## Configuring Communication Parameters

When configuring the NA-4020 or NA-4021 for the first time, connect the ioLogik directly to your PC's RS-232 port. The ioLogik side of the connection requires a DB9 connector. If your computer does not have an RS-232 port, you can install a Moxa multiport serial board (for example, the CP-132U) or use a Moxa USB-to-serial hub (for example, the NPort 1220).

### Connecting a Single Serial I/O Server



A DIP switch on the NA-4020/4021's front panel allows you to configure the parameters manually.

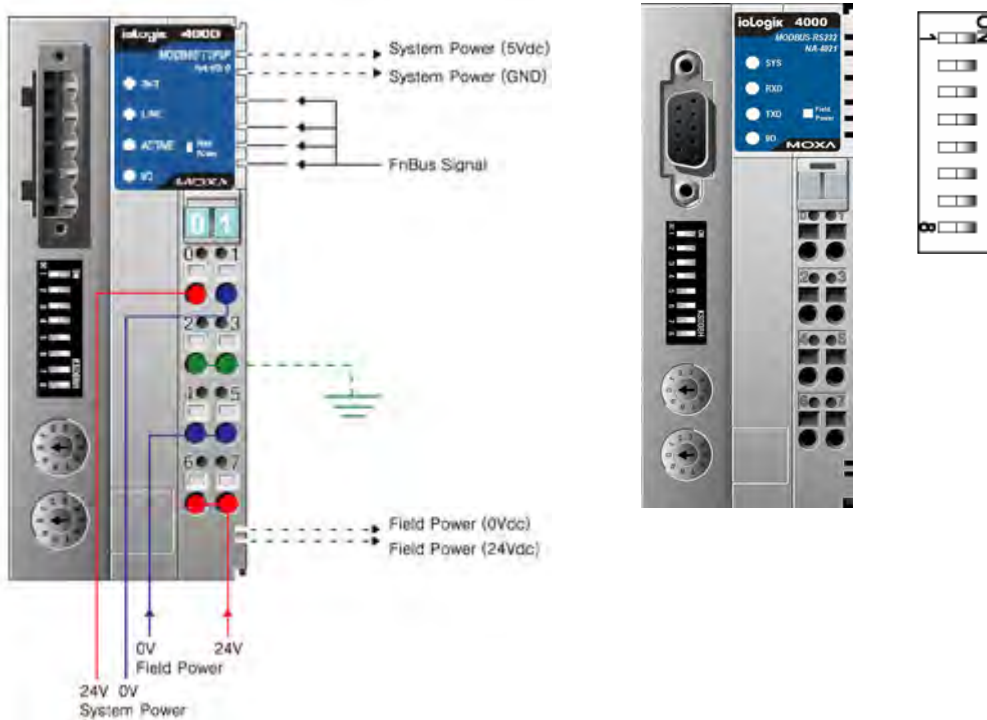

**DIP Switch Configuration Table**

No.	Configuration	Settings																																				
1-3	Baudrate	<table border="1"> <thead> <tr> <th>1</th> <th>2</th> <th>3</th> <th></th> </tr> </thead> <tbody> <tr> <td>OFF</td> <td>OFF</td> <td>OFF</td> <td>1200 bps</td> </tr> <tr> <td>ON</td> <td>OFF</td> <td>OFF</td> <td>2400 bps</td> </tr> <tr> <td>OFF</td> <td>ON</td> <td>OFF</td> <td>4800 bps</td> </tr> <tr> <td>ON</td> <td>ON</td> <td>OFF</td> <td>9600 bps</td> </tr> <tr> <td>OFF</td> <td>OFF</td> <td>ON</td> <td>19200 bps</td> </tr> <tr> <td>ON</td> <td>OFF</td> <td>ON</td> <td>38400 bps</td> </tr> <tr> <td>OFF</td> <td>ON</td> <td>ON</td> <td>57600 bps</td> </tr> <tr> <td>ON</td> <td>ON</td> <td>ON</td> <td>115200 bps</td> </tr> </tbody> </table>	1	2	3		OFF	OFF	OFF	1200 bps	ON	OFF	OFF	2400 bps	OFF	ON	OFF	4800 bps	ON	ON	OFF	9600 bps	OFF	OFF	ON	19200 bps	ON	OFF	ON	38400 bps	OFF	ON	ON	57600 bps	ON	ON	ON	115200 bps
1	2	3																																				
OFF	OFF	OFF	1200 bps																																			
ON	OFF	OFF	2400 bps																																			
OFF	ON	OFF	4800 bps																																			
ON	ON	OFF	9600 bps																																			
OFF	OFF	ON	19200 bps																																			
ON	OFF	ON	38400 bps																																			
OFF	ON	ON	57600 bps																																			
ON	ON	ON	115200 bps																																			
4	Watchdog	ON: Enable OFF: Disable																																				
5 to 7	Communication Parameters	<table border="1"> <thead> <tr> <th>5</th> <th>6</th> <th>7</th> <th></th> </tr> </thead> <tbody> <tr> <td>OFF</td> <td>OFF</td> <td>OFF</td> <td>None, 8 data bits, 1 stop bit</td> </tr> <tr> <td>ON</td> <td>OFF</td> <td>OFF</td> <td>Even, 8 data bits, 1 stop bit</td> </tr> <tr> <td>OFF</td> <td>ON</td> <td>OFF</td> <td>Odd, 8 data bits, 1 stop bit</td> </tr> <tr> <td>ON</td> <td>ON</td> <td>OFF</td> <td>None, 8 data bits, 2 stop bits</td> </tr> <tr> <td>OFF</td> <td>OFF</td> <td>ON</td> <td>None, 7 data bits, 2 stop bits*</td> </tr> <tr> <td>ON</td> <td>OFF</td> <td>ON</td> <td>Even, 7 data bits, 1 stop bit*</td> </tr> <tr> <td>OFF</td> <td>ON</td> <td>ON</td> <td>Odd, 7 data bits, 1 stop bit*</td> </tr> <tr> <td>ON</td> <td>ON</td> <td>ON</td> <td>None, 8 data bits, 1 stop bit</td> </tr> </tbody> </table>	5	6	7		OFF	OFF	OFF	None, 8 data bits, 1 stop bit	ON	OFF	OFF	Even, 8 data bits, 1 stop bit	OFF	ON	OFF	Odd, 8 data bits, 1 stop bit	ON	ON	OFF	None, 8 data bits, 2 stop bits	OFF	OFF	ON	None, 7 data bits, 2 stop bits*	ON	OFF	ON	Even, 7 data bits, 1 stop bit*	OFF	ON	ON	Odd, 7 data bits, 1 stop bit*	ON	ON	ON	None, 8 data bits, 1 stop bit
5	6	7																																				
OFF	OFF	OFF	None, 8 data bits, 1 stop bit																																			
ON	OFF	OFF	Even, 8 data bits, 1 stop bit																																			
OFF	ON	OFF	Odd, 8 data bits, 1 stop bit																																			
ON	ON	OFF	None, 8 data bits, 2 stop bits																																			
OFF	OFF	ON	None, 7 data bits, 2 stop bits*																																			
ON	OFF	ON	Even, 7 data bits, 1 stop bit*																																			
OFF	ON	ON	Odd, 7 data bits, 1 stop bit*																																			
ON	ON	ON	None, 8 data bits, 1 stop bit																																			
8	Modbus protocol	ON: Modbus/ASCII OFF: Modbus/RTU																																				

\*Only Modbus/ASCII is supported when data bits is set to 7.

**NOTE** The default values are: 9600, N, 8, 1, Watchdog disabled, Modbus/RTU.

**NOTE** ioAdmin only operates under Modbus/RTU.

The next step is to configure the Unit ID for the I/O Server. On a Modbus/RTU/ASCII serial network, each node must have a unit ID that ranges from 01 to 99. Use a screw driver to rotate the switch and set the Unit ID. The upper switch represents the high digit, whereas the lower switch represents the low digit.

Note that the address 00, which is usually used in the Modbus/RTU/ASCII master, is reserved for broadcasts.

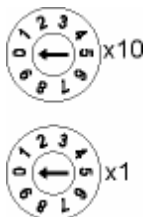

## Linking the RS-485/232 I/O Server to ioAdmin

After you connect the RS-232/485 I/O server to the host computer's COM port (e.g., COM2) via a DB9 cable, and the I/O server is powered on, you can start up ioAdmin. Set the communication parameters to 9600, N, 8, 1 for both the host computer's COM port and the serial network adaptor.

### Starting ioAdmin

To start ioAdmin, click **Start** → **Program Files** → **Moxa** → **IO Server** → **Utility** → **ioAdmin**.

## Linking to the RS-232/485 Server

There are two ways to link to the RS-485/232 I/O server: (1) with Auto Search, and (2) by entering the Unit ID manually.

### Linking with Auto Search

To start the Auto Search function, click on **Auto Scan Active Ethernet I/O Server** under System.

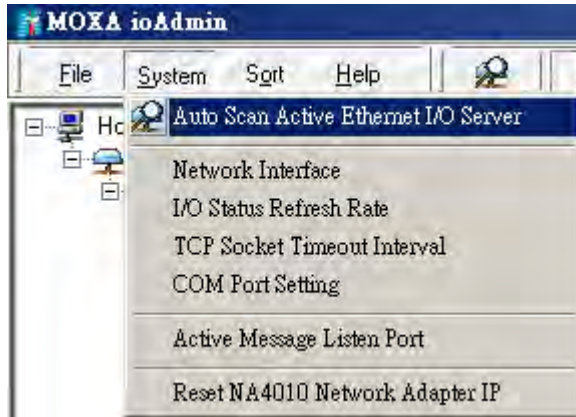

ioAdmin can automatically allocate available COM ports on the host computer and scan Unit IDs from 01 to 99 for each COM port. However, it could take a long time to finish the process. A more efficient and faster method is to select **Only Search: COMx** and search designated COM ports. Note that ioAdmin supports Modbus/RTU. In a Modbus/ASCII environment, configure the network adaptor using Modbus/RTU, and then switch back to Modbus/ASCII for field operation.

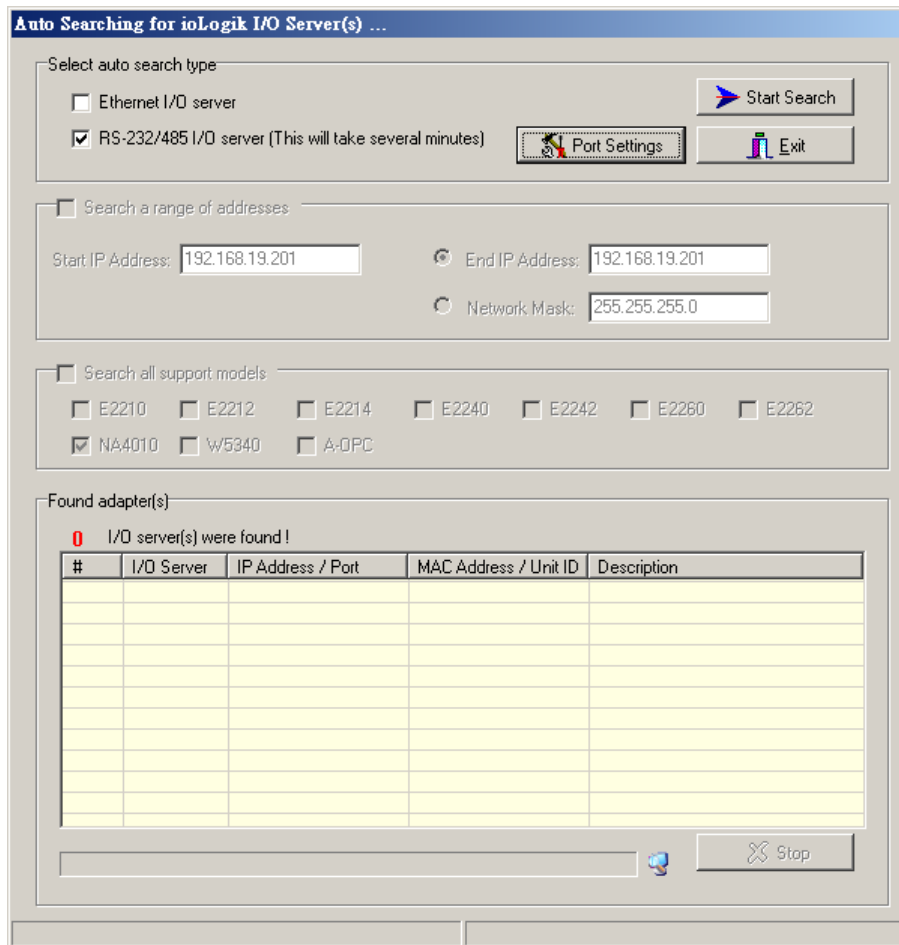

Click **Port Settings** to configure the COM port and baudrate, data bit stop bit, and parity. Click **Start Search** to search for connected RS-485 or R-232 I/O servers.



### Linking Manually

To add RS-485/232 I/O servers to ioAdmin manually, click the right mouse button, and then click on the ioLogik in the left ioAdmin frame. Click on NA-4021, choose the connected COM port number, and then select the Unit ID for Modbus address.

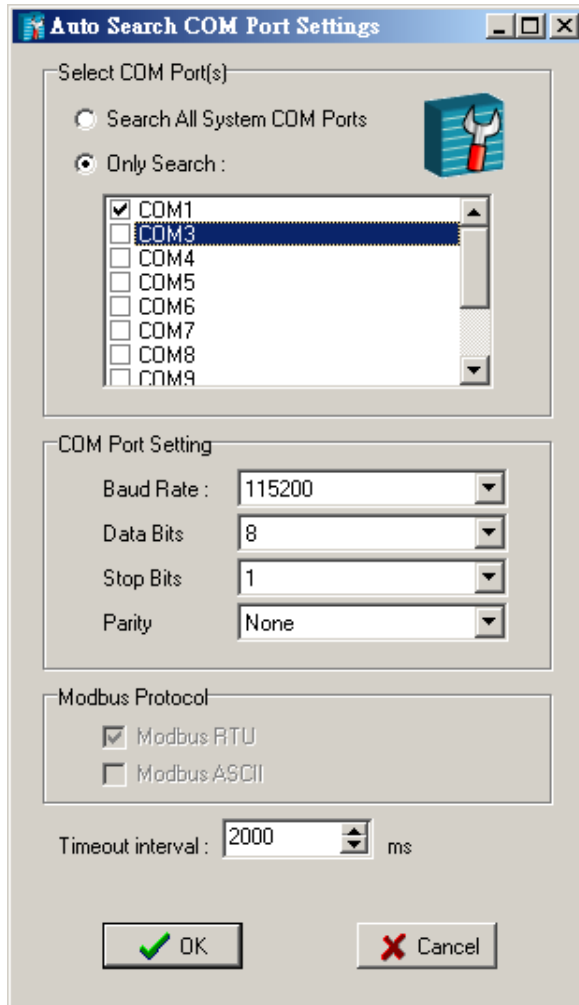

Once the RS-232/485 I/O server is connected to ioAdmin, the following screen will appear.

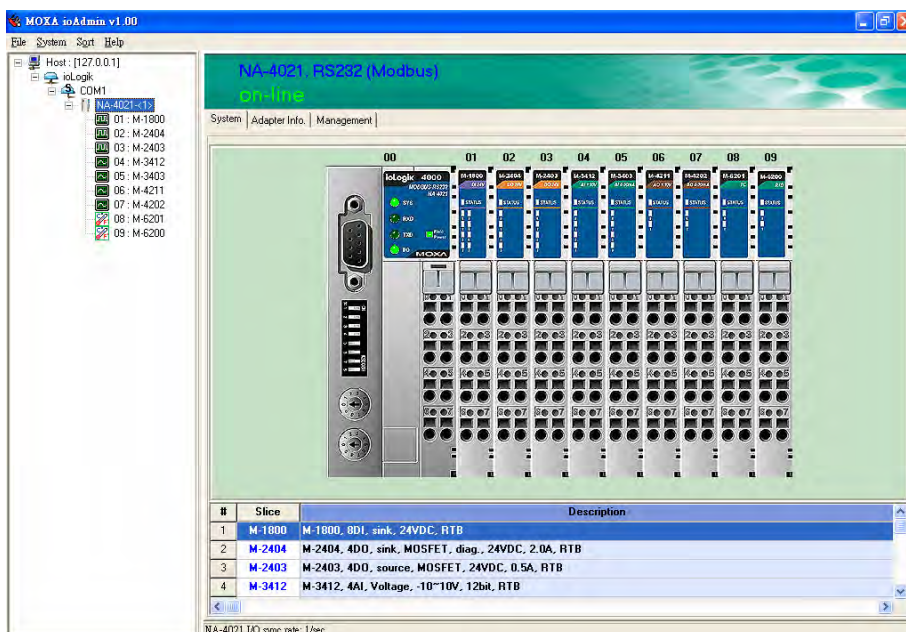

The left ioAdmin frame shows all I/O servers found on the network. The upper right frame indicates the combination of all I/O modules by slot number. The lower right frame lists detailed information for installed I/O modules. Position the cursor over any I/O module to display the model name and description automatically.

At this point, your I/O Server should be up and running.

## Password Protection

Watchdog configuration, Reset to Default, and Restart System are password protected. By default, the password is blank. However, you will still need to click on Login to show the Watchdog tab.

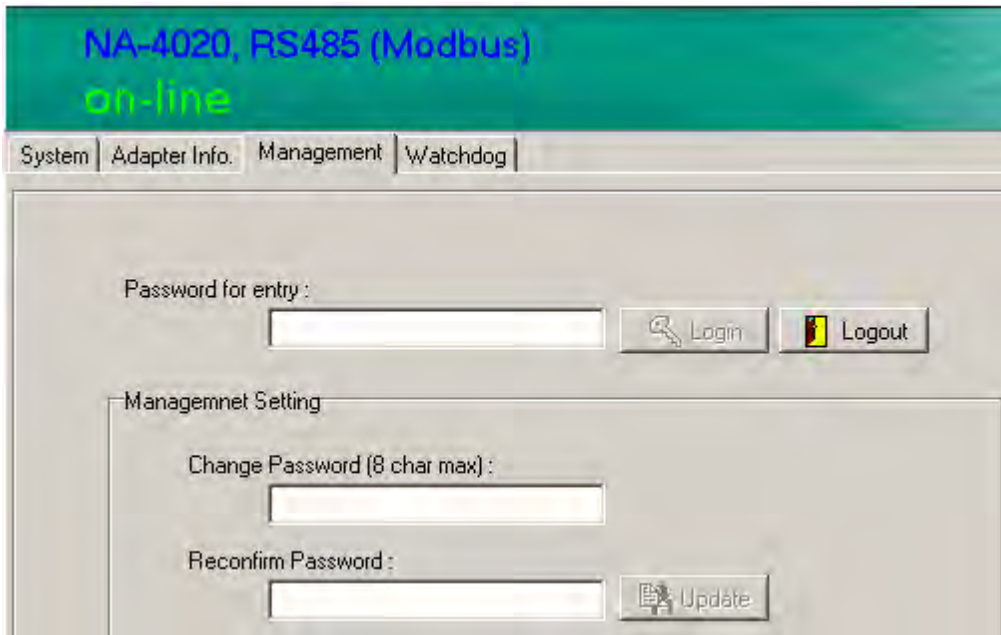

## Reset to Default

The network adaptor settings, watchdog timer setting, I/O module safety status, and temperature sensor parameters are stored in the network adaptor. Right click on the target I/O server, and then click on **Reset to Default** to proceed. You may need to wait 10 seconds or longer. ioAdmin will reconnect the I/O server automatically. Note that this function requires password authorization to activate.

### Default Settings

<b>Baudrate</b>	9600
<b>Communication parameters</b>	N,8,1
<b>Modbus protocol</b>	RTU
<b>Modbus watchdog</b>	disable
<i>Note: The above parameters are set with the network adaptor's DIP switch.</i>	
<b>Watchdog timeout</b>	5 sec (50 x 100ms)
<b>Password</b>	(Empty)
<i>Note: The above parameters are set by software.</i>	

## Restarting the System

In general, you don't need to restart the I/O server when changing I/O module configurations. However, when the I/O server indicates an I/O error, you may use this function to restart the I/O server system remotely.

**Right click** on the target I/O server and then click **Restart System** to proceed. You may need to wait 10 seconds or longer. ioAdmin will reconnect to the I/O Server automatically.

Note that this function requires password authorization to activate.

## Deleting an I/O Server from the List

Sometimes too many I/O servers appear in the left ioAdmin frame. To delete an I/O server from the list for easier management, **right click** on the target I/O server. Click on **Disconnect**, and then click on **Delete I/O Server**. The target I/O server will be removed from the list.

**NOTE** The ioLogik must first be disconnected to use this function.

## Watchdog Timer

The Watchdog timer monitors the Modbus/RTU or Modbus/ASCII connection between the Network Adaptor and the host computer. The default is **off**.

When there is no query from the host computer over a preset time (in 100 msec increments), the Network Adaptor will set all digital output and analog output values to a predefined Safe Status. Whether or not the Network Adaptor is operational and ready for normal operation depends on the host computer. The maximum Timeout Value is 65535, which equals 6553.5 seconds.

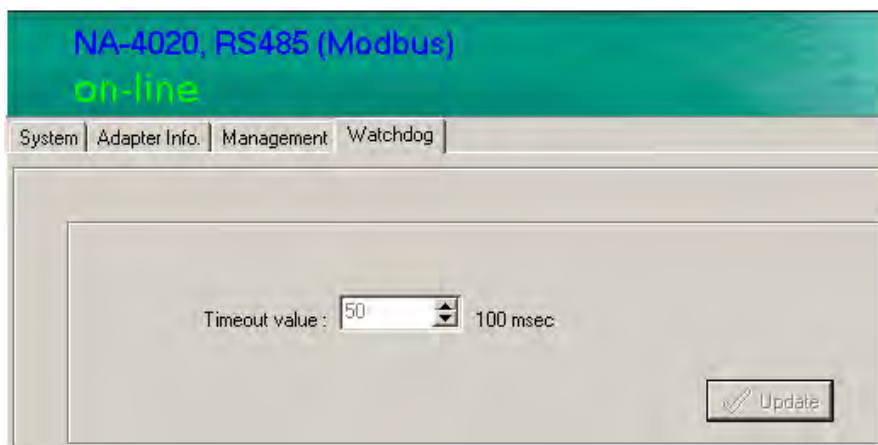

## Firmware Update

Firmware updates for the NA-4020 and NA-4021 are not available to end users. If you need to update the firmware, please contact your local distributor for service.

## I/O Status Refresh Rate

This parameter determines how often the ioAdmin utility polls all connected I/O servers. The default value is 50 (500 msec). To change the configuration, click on **Data Refresh Rate** in the System menu, and then adjust the data refresh rate. Note that the units are in 10 msec increments, so if you enter 50, the refresh rate changes to 0.5 sec.

# Modbus Address Mapping

## Finding a Modbus Address for I/O Channels

The Modbus Address for each I/O channel is arranged dynamically by the network adaptor according to the slot sequence and the type of I/O module. Changing an Ethernet network adaptor to an RS-485 or RS-232 network adaptors will not change the Modbus address mapping.

The Modbus Address mapping for I/O modules can be found on "Modbus Address" tab.

Channel #	WORD Address/bit offset	BIT Address	Size (Bit)
#0	0x0800/0x00	0x1000	0x0001
#1	0x0800/0x01	0x1001	0x0001
#2	0x0800/0x02	0x1002	0x0001
#3	0x0800/0x03	0x1003	0x0001

Address #	Value/Status	Access	Description
0x2037	1.005	Read	Firmware Revision

There are three columns for Modbus Address. According to the Modbus standard, there are two methods for accessing an I/O channel: (1) access by Register, and (2) access by Coil.

**NOTE** For more information, refer to the Modbus protocol specifications.

## Exporting Modbus Address Settings

Modbus Addresses for I/O channels are required when you want to access the I/O status with SCADA software. However, it's not easy to memorize all of the addresses for each I/O channel. For this reason, ioAdmin allows you to export a text file containing the installed I/O modules and their Modbus addresses. The following example is an exported system configuration file.

### 3. Modbus address table

Slot No.	Channel No.	I/O type	Modbus Addr.(WORD)	Modbus Addr.(BIT)	I/O Data Length
01	00	Input	0x0000/0x00	0x0000	0x0010
01	01	Input	0x0001/0x00	0x0010	0x0010
01	02	Input	0x0002/0x00	0x0020	0x0010
01	03	Input	0x0003/0x00	0x0030	0x0010
02	00	Input	0x0004/0x00	0x0040	0x0010
02	01	Input	0x0005/0x00	0x0050	0x0010
03	00	Input	0x0006/0x00	0x0060	0x0001
03	01	Input	0x0006/0x01	0x0061	0x0001
03	02	Input	0x0006/0x02	0x0062	0x0001
03	03	Input	0x0006/0x03	0x0063	0x0001
03	04	Input	0x0006/0x04	0x0064	0x0001

## Configuring I/O Modules

---

In this chapter, we describe the common features related to using ioAdmin to configure I/O modules.

The following topics are covered in this chapter:

- ❑ **On-Line Wiring Guide**
- ❑ **Digital Input Modules**
- ❑ **Digital Output Modules**
- ❑ **Digital Output Module Safe Status**
- ❑ **Analog Input Modules**
- ❑ **Analog Output Modules**
- ❑ **Analog Output Module Safe Status**
- ❑ **Temperature Sensing Modules**
  - RTD
  - Thermocouple

# On-Line Wiring Guide

ioAdmin has a graphical interface that features the “What You See Is What You Install” philosophy. The ioLogik 4000 is easy-to-use, and ioAdmin comes with an on-line I/O wiring guide that makes your job easy. Use the mouse to move the cursor over any of the I/O modules and then click the right mouse button to display a **Wiring Guide**.

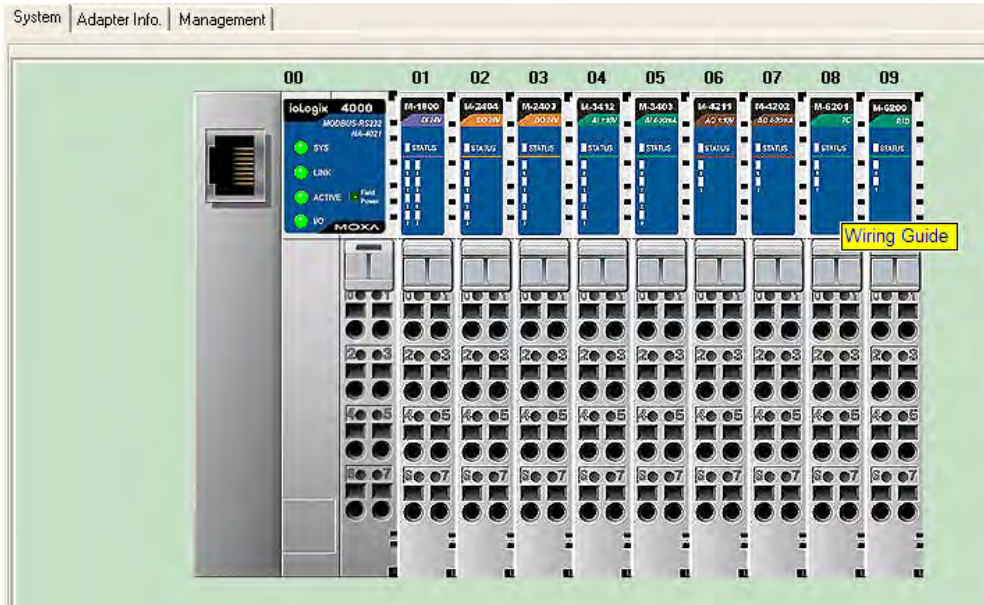

Click on the wiring guide to show a help file for that model.

**M-6201 2 analog input, Thermocouple, removable terminal block**

<p><b>System wiring</b></p>	<p><b>Input Specification</b></p> <p>Sensor types : Type J/K/T/E/R/S/B/N/L/U/C/D mV input 10uV/bit, 1uV/bit, 2uV/bit</p> <p>Data format : 16 bit integer (2 s compliment)</p> <p>Resolution : 0.1C / 10m ohm</p> <p>Accuracy : +/- 0.1%, FSR @ 25C +/- 0.3%, FSR @ 0C, 60C</p> <p>Input impedance : -</p> <p>Conversion time : 200m sec. / all channel</p> <p>Diagnostic : Range over (if range over, data=Dx8000)</p> <p><b>General Specification</b></p> <p>Power dissipation : Max. 70mA @ 5.0VDC</p> <p>Isolation : I/O to logic: 2kVrms optical isolation</p> <p>Wiring : I/O cable max. AWG14</p>
-----------------------------	---

# Digital Input Modules

ioAdmin can monitor the status of each digital input channel. We use M-1800 to illustrate. To check the status of a DI channel, click on the I/O module on the main page to display the I/O status on the "I/O Status" tab.

M-1800, 8DI, sink, 24VDC, RTB  
on-line

I/O Status | Modbus Address

Channel #	Value
#0	0
#1	0
#2	0
#3	0
#4	0
#5	0
#6	0
#7	0

To check the Modbus Address, click on the "Modbus Address" tab.

M-1800, 8DI, sink, 24VDC, RTB  
on-line

I/O Status | Modbus Address

Input Register Address

Channel #	WORD Address/bit offset	BIT Address	Size (Bit)
#0	0x0000/0x00	0x0000	0x0001
#1	0x0000/0x01	0x0001	0x0001
#2	0x0000/0x02	0x0002	0x0001
#3	0x0000/0x03	0x0003	0x0001
#4	0x0000/0x04	0x0004	0x0001
#5	0x0000/0x05	0x0005	0x0001
#6	0x0000/0x06	0x0006	0x0001
#7	0x0000/0x07	0x0007	0x0001

Slice Diagnosis

Address #	Value/Status	Access	Description
0x2017	1.005	Read	Firmware Revision

Related Models	Digital Input
M-1800	8 DI, sink, 24 VDC, RTB
M-1801	8 DI, source, 24 VDC, RTB
M-1600	16 DI, sink, 24 VDC, RTB
M-1601	16 DI, source, 24 VDC, 20-pin
M-1450	4 DI, 110 VAC, RTB
M-1451	4 DI, 220 VAC, RTB

# Digital Output Modules

ioAdmin can monitor the status of each digital output channel. We use M-2404 to illustrate. To check the DI channel status, click on the I/O module on the main page. You will see the I/O status on the "I/O Status" tab.

Channel #	Safe Mode	Safe Status
#0	Safe Status	OFF
#1	Safe Status	OFF
#2	Safe Status	OFF
#3	Safe Status	OFF

To check the Modbus Address, click on the "Modbus Address" tab.

Channel #	WORD Address/bit offset	BIT Address	Size (Bit)
#0	0x0800/0x00	0x1000	0x0001
#1	0x0800/0x01	0x1001	0x0001
#2	0x0800/0x02	0x1002	0x0001
#3	0x0800/0x03	0x1003	0x0001

Address #	Value/Status	Access	Description
0x2037	1.005	Read	Firmware Revision



# Digital Output Module Safe Status

The digital output channel can be set to safe status when the following situations occur.

- Modbus watchdog is activated
- An I/O error is detected

You may set the digital output status to following settings.

- Hold last state
- ON or OFF

Note that the configuration applies to all channels within the module.

You can test to make sure the digital output channel works over the network. Click on the "Test" tab on the "Config" page. Press the switch, and then press "Test." At this point, you can change the status of the digital output point.

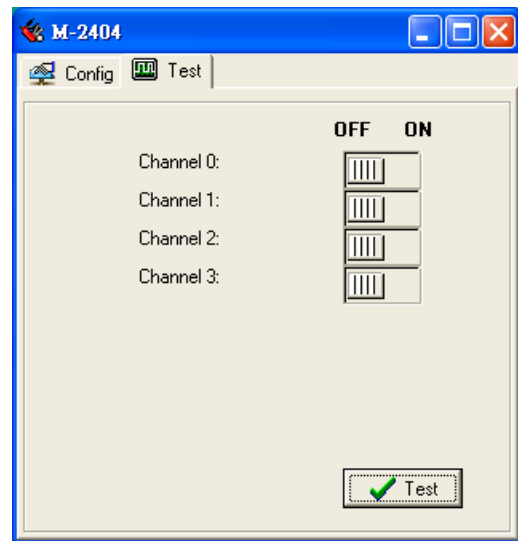
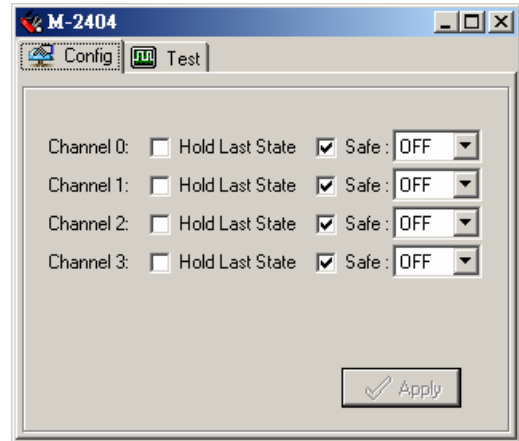

Related Models	Digital Input
M-2800	8 DOs, sink, MOSFET, 24 VDC, 0.5 A, RTB
M-2801	8 DOs, source, MOSFET, 24 VDC, 0.5 A, RTB
M-2600	16 DOs, sink, MOSFET, 24 VDC, 0.3 A, 20 pins
M-2601	16 DOs, source, MOSFET, 24 VDC, 0.3 A, 20 pins
M-2450	4 DOs, relay, 230 VAC, 24 VDC, 2.0 A, RTB

# Analog Input Modules

ioAdmin can monitor the status of each analog input channel. We use M-3412 to illustrate. To check the status of the DI channel, click on the I/O module on the main page. The I/O status is located on the "I/O Status" tab.

M-3412, 4AI, Voltage, -10~10V, 12bit, RTB  
on-line

I/O Status | Modbus Address

Channel #	Value (RAW / Voltage)
#0	670 / 3.28 V
#1	-1 / 0.00 V
#2	-1 / 0.00 V
#3	-1 / 0.00 V

To check the Modbus Address, click on the "Modbus Address" tab.

M-3412, 4AI, Voltage, -10~10V, 12bit, RTB  
on-line

I/O Status | Modbus Address

**Slice Input Register Address**

Channel #	WORD Address/bit offset	BIT Address	Size [Bit]
#0	0x0001/0x08	0x0018	0x0010
#1	0x0002/0x08	0x0028	0x0010
#2	0x0003/0x08	0x0038	0x0010
#3	0x0004/0x08	0x0048	0x0010

**Slice Diagnosis**

Address #	Value/Status	Access	Description
0x2077	1.008	Read	Firmware Revision

Related Models	Digital Input
M-3802	8 AIs, current, 4-20 mA, 12-bit, RTB
M-3810	8 AIs, voltage, 0-10 V, 12-bit, RTB

# Analog Output Modules

This section describes how to configure an analog output module. We use the M-4211 to illustrate. To check the status of an analog output channel, click on the I/O module on the main page. The I/O status will be displayed on the "I/O Status" tab.

M-4211, 2AO, Voltage, -10~10V, 12bit, RTB  
on-line

I/O Status | Config | Modbus Address

Channel #	Value (RAW / Voltage)
#0	0 / 0.00 V
#1	0 / 0.00 V

To check the Modbus Address, click on the "Modbus Address" tab.

M-4211, 2AO, Voltage, -10~10V, 12bit, RTB  
on-line

I/O Status | Config | Modbus Address

**Output Register Address**

Channel #	WORD Address/bit offset	BIT Address	Size [Bit]
#0	0x0801/0x00	0x1010	0x0010
#1	0x0802/0x00	0x1020	0x0010

**Slice Diagnosis**

Address	Value/Status	Access	Description
0x20B7	1.008	Read	Firmware Revision

# Analog Output Module Safe Status

The analog output channel can be set to safe status when the following situations occur.

- Modbus watchdog is activated
- An I/O error is detected

You may set the analog output status to the following settings.

- Hold last state
- Safe value
- Low limit
- High limit

**Low Limit** represents the lowest value for the analog out module. For a 0 to 10 V analog output module, the Low Limit is 0 V.

**High Limit** represents the highest value for the analog output module. For a 0 to 10 V analog output module, the High Limit is 10 V.

You can test if the analog output channel really works over the network. Click on the “Test” tab on the “Config” page. Scroll the output level, and then press “Test.” At this point, you can change the level of the analog output point.

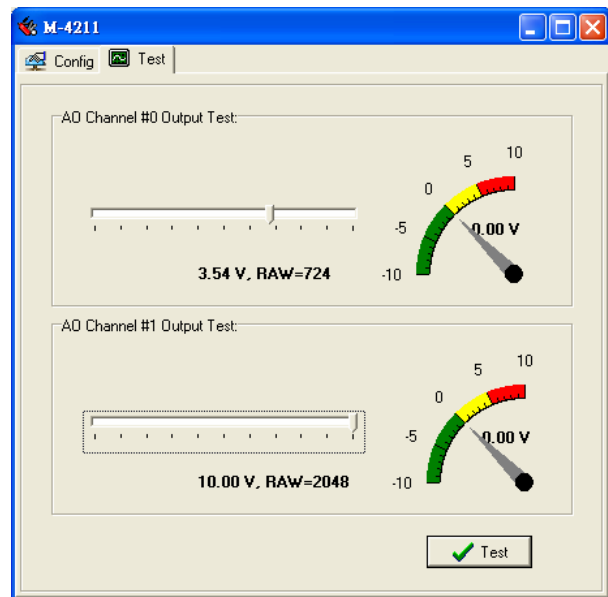
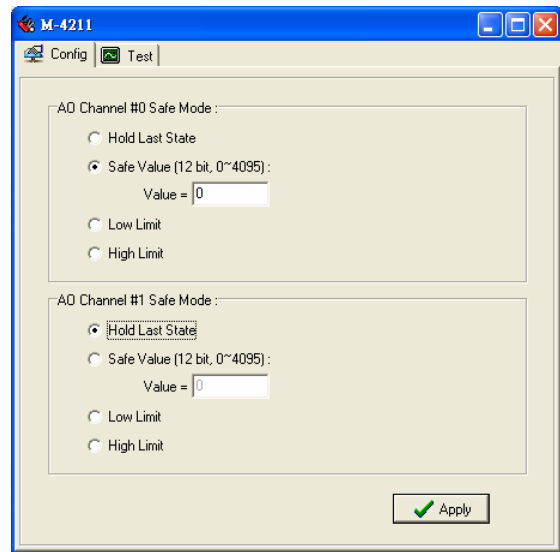

Related Models	Analog Output
M-4402	4 AOs, 4-20 mA, 12-bit, RTB
M-4410	4 AOs, voltage, 0-10 V, 12-bit, RTB

# Temperature Sensing Modules

The ioLogik 4000 provides RTD (Resistance Temperature Detector) and TC (Thermocouple) temperature sensing modules.

## RTD

To check the temperature status, click on the I/O module from the main page. The temperature is on the "I/O Status" tab. When the sensor is not connected or the wiring is broken, the value is "0x8000".

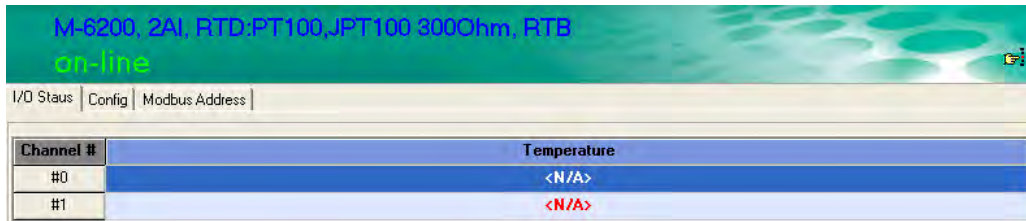

To check the Modbus Address, click on the "Modbus Address" tab.

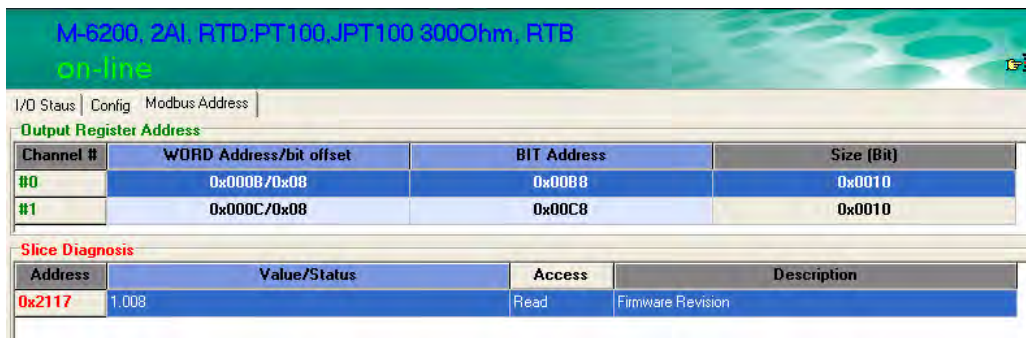

The RTD module supports different kinds of temperature sensors. To configure the sensor type, click on **config**.

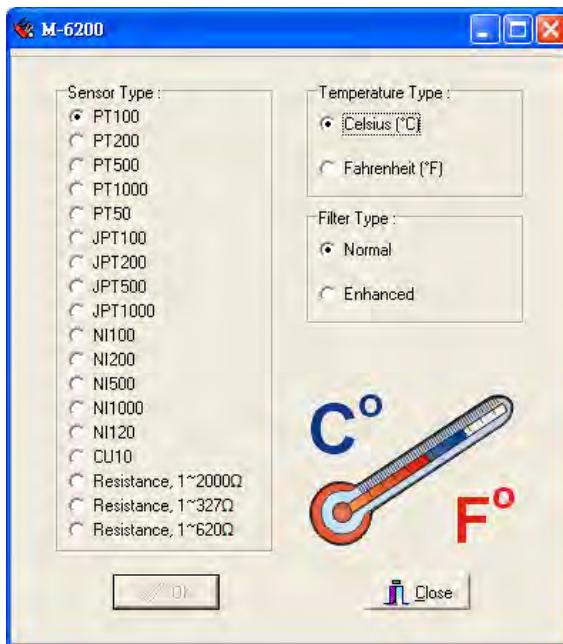

On this page, you can set up the sensor types and temperature unit. Note that the configuration applies to all channels on the same module. The related model is M-6200. The **FilterType** represents different sampling times. In Normal mode, the conversion time is about 200 msec. In Enhanced mode, the conversion time will be about double, or around 400 ms.

## Thermocouple

To check the temperature status, click on the I/O module from the main page. The temperature will be shown on the "I/O Status" tab.

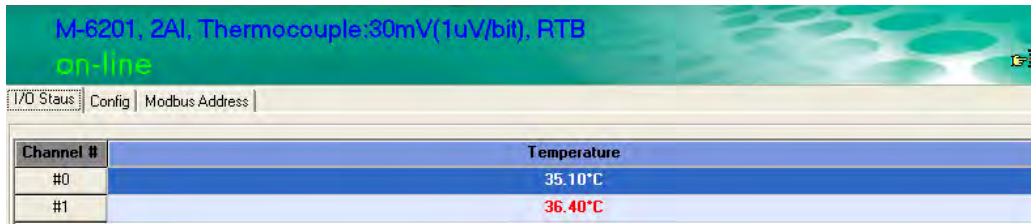

Channel #	Temperature
#0	35.10°C
#1	36.40°C

To check the Modbus Address, click on the "Modbus Address" tab.

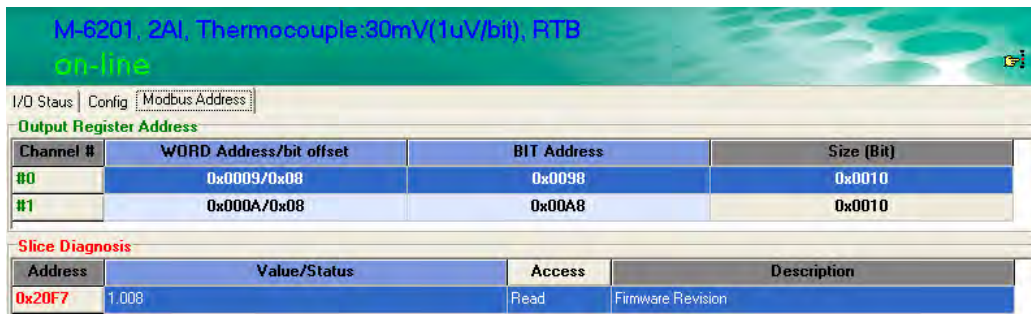

Channel #	WORD Address/bit offset	BIT Address	Size (Bit)
#0	0x0009/0x08	0x0098	0x0010
#1	0x000A/0x08	0x00A8	0x0010

Address	Value/Status	Access	Description
0x20F7	1.008	Read	Firmware Revision

The thermocouple module supports different kinds of temperature sensor. To configure the sensor type, click on **config**.

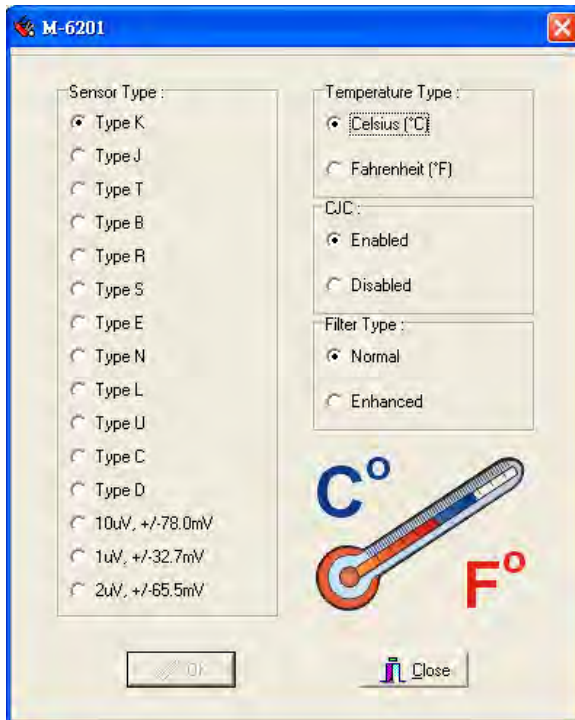

On this page, you can set up the sensor types and the temperature unit. Note that the configuration applies to all channels on the same module. The related model is M-6201.

The **FilterType** represents the different sampling times. In Normal mode, the conversion time is about 200 ms. In Enhanced mode, the conversion time will be about double, or around 400 ms. The thermocouple temperature sensor is noise sensitive. Using Enhanced Mode can increase stability of the readings. CJC should always be enabled.

## MXIO DLL Library

---

The following topics are covered in this chapter:

### □ Overview

- What is MXIO DLL Library?
- How to install MXIO DLL Library

### □ MXIO Function Groups

- System Commands
- Modbus Command Sets
- Direct I/O Command Sets

# Overview

## What is MXIO DLL Library?

MXIO DLL Library is a Windows library specially designed for programmers who are not familiar with the Modbus protocol, but who need to create applications to get real world temperature, data, and on/off control signals.

The MXIO DLL supports Visual Basic, Visual C++, and Borland C++ Builder.

## How to install MXIO DLL Library

The MXIO DLL Library comes with the ioAdmin software utility. It is installed in the directory **Start → Programs → Moxa → IO Server → Library**. Refer to MXIO DLL help for details.

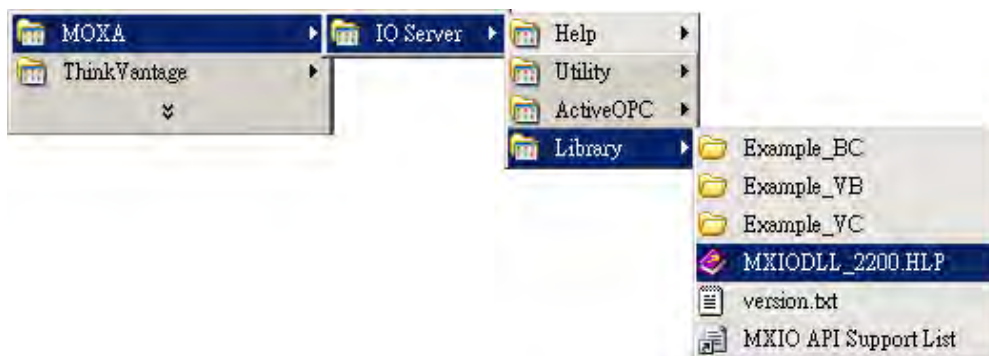

# MXIO Function Groups

## System Commands

RS-485/RS-232 I/O Connect Commands
MXSIO_OpenCommPort
MXSIO_CloseCommport
MXSIO_Connect
MXSIO_Disconnect
Ethernet I/O Connect Commands
MXEIO_Init
MXEIO_Exit
MXEIO_Connect
MXEIO_Disconnect
MXEIO_CheckConnection
General Commands
MXIO_GetDllVersion
MXIO_GetModuleType

## Modbus Command Sets

MXIO_ReadCoils
MXIO_WriteCoils
MXIO_ReadRegs
MXIO_WriteRegs

## Direct I/O Command Sets

<b>Digital Input Commands</b>
DI_Reads DI_Read
<b>Digital Output Commands</b>
DO_Reads DO_Read DO_Writes DO_Write
<b>Analog Input Commands</b>
AI_Reads AI_Read
<b>Analog Output Commands</b>
AO_Reads AO_Read AO_Writes AO_Write
<b>RTD Commands</b>
RTD_Reads RTD_Read
<b>Thermocouple Commands</b>
TC_Reads TC_Read
<b>Special Commands for ioLogik 4000</b>
Adp4K_ReadFirmwreRevisi on Adp4K_ReadFirmwareDate Adp4K_ReadSlotAmount Adp4K_ReadStatus Adp4K_ReadAlarmedSlot



# A

## Pinouts and Cable Wiring

---

The following topics are covered in this appendix:

- **Port Pinout Diagrams**
  - Ethernet Port Pinouts
  - Serial Port Pinouts
- **Ethernet Cable Wiring Diagrams**

# Port Pinout Diagrams

## Ethernet Port Pinouts

Pin	Signal
1	Tx+
2	Tx-
3	Rx+
6	Rx-

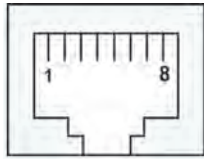

## Serial Port Pinouts

### NA-4020 RS-485 Network Adaptor Pin Assignment

**RS485 Connector**

- RS485+ —
- RS485- —
- GND —
- Shield —
- FG —

Dsub 5-Pin (Female)	Signal Name	Description
1	RS485+	In/Out, Transceiver Data High
2	RS485-	In/Out, Transceiver Data Low
3	GND	Signal Common
4	Shield	Shield
5	FG	Frame Ground. Internally shorted with Shield

### NA-4021 RS-232 Network Adaptor Pin Assignment

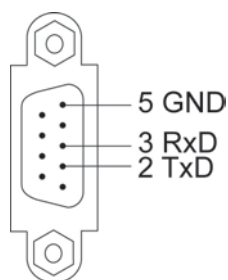

# Ethernet Cable Wiring Diagrams

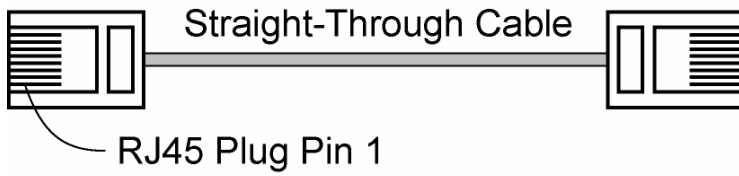

### Cable Wiring

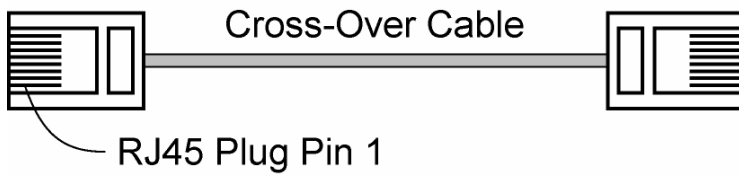
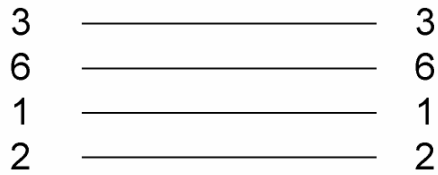

### Cable Wiring

